

Sample Final Examination

There are six questions. Be precise, show every step, and state your assumptions (if any), to get full credit.

- (20 pts) Given a four-input Boolean function, $f(A, B, C, D) = \sum m(0, 3, 5, 7, 11, 12, 13, 15)$
 - Implement the function using a 16:1 multiplexer.
 - Implement using an 8:1 multiplexer.
 - Implement using a 4:1 multiplexer.
 - Implement the function using a 4:16 decoder and an OR gate.
- (10 pts) Make the following two-level logic designs hazard free under one input switching:
 - $F(A, B, C, D) = \sum m(0, 1, 2, 5, 8, 9, 10, 13)$
 - $G(A, B, C, D) = (A + C)(\bar{A} + \bar{D})(\bar{B} + \bar{C} + D)$
- (10 pts) Design a positive edge-triggered T flip-flop by using only NAND gates.
- (20 pts) Minimize the state diagram in Figure Ex9.5 on Katz page 489. Then make a state assignment and implement it by using D flip-flops.
- (20 pts) Model the given designs in VHDL language.

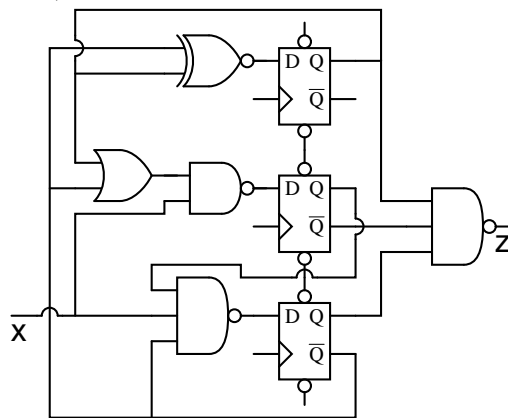

(a)

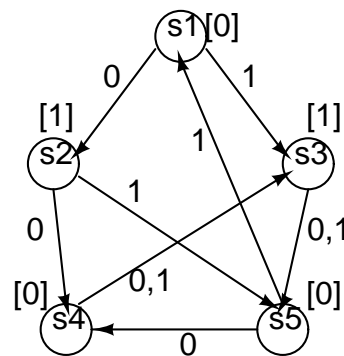

(b)

- (20 pts) A sequential circuit has two inputs and two outputs. The inputs (X_1, X_2) represent a 2-bit binary number, N . If the present value of N is greater than the previous value, then $Z_1 = 1$. If the present value of N is less than the previous value, then $Z_2 = 1$. Otherwise, Z_1 and Z_2 are 0.
 - Derive a Mealy machine state diagram and make sure it is minimized.
 - Derive a Moore machine state diagram and make sure it is minimized.