

# Performance of Turbo Decision-Feedback Detection for Downlink OFDM

Koushik Sil, Manish Agarwal, Dongning Guo, and Michael L. Honig  
Department of Electrical Engineering and Computer Science  
Northwestern University  
Evanston, Illinois 60208, USA

Wiroonsak Santipach  
Department of Electrical Engineering  
Faculty of Engineering, Kasetsart University  
Bangkok 10900, Thailand

**Abstract**—This work studies the performance of multiuser detection and decoding in the downlink of cellular systems based on orthogonal frequency-division multiplexing (OFDM). Of particular interest is a worst case scenario where the desired user is at the cell boundary and subject to an equally strong interferer from a neighboring cell. A flexible iterative Turbo decision-feedback equalizer (DFE) is proposed and studied numerically, which exhibits good error performance and resilience to fading, requires moderate training and low complexity, and accommodates multiple antennas easily. The scheme performs well without knowledge of the pilots of interfering signals from other cells, which is typically unavailable in practice, while such knowledge may improve the performance significantly. Furthermore, in the absence of knowledge of pilots for the out-of-cell interference, it is found that estimating the filter coefficients of the DFE directly is superior to deriving the coefficients from estimates of the instantaneous channel gains.

## I. INTRODUCTION

Consider the downlink of a multiantenna OFDM system. If there is only one cell and a single base station, with judicious scheduling and use of guard times, communication is essentially single-user at any given time. Of particular interest in this work is, however, the multi-cell situation where signals from two base stations interfere at a given receiver. This occurs, for example, when the receiver is located near the boundary between two cells and receives (perhaps equally strong) signals from two base stations serving itself and another receiver in a different cell, respectively. What make things worse are channel variations due to fading and the absence of knowledge about the pilots associated with other-cell interferers (because of practical reasons). Successful treatment of this worst-case scenario is quintessential for enhancing the performance of cellular OFDM-based systems, which will be supporting the majority of next generation mobiles.

The goal of this work is to identify a practical transceiver structure with good performance in the aforementioned worst-case scenarios. Specifically, we consider the use of error-control codes, interleaving and multiple antennas. We propose an iterative Turbo decision-feedback equalizer (DFE) and study its performance through simulation under a set of assumptions, including the existence of a single (strong) interferer, independent OFDM subchannels and independent Rayleigh block fading such that a codeword derived from a rate-1/2 convolutional code spans the duration of several blocks, (These assumptions can be easily modified under the framework of this simulation study.)

Turbo equalization with several variations in structure and application has been considered in [1]–[5]. In [1], a Turbo equalization structure was proposed for single-user MIMO channels with intersymbol interference. This work extends [1] to a downlink MIMO-OFDM system with emphasis on other-cell-interference cancellation. Some of the recent related works are [6]–[10]. In particular, [6] deals with bit-interleaved coded OFDM with MMSE receivers but does not consider decision feedback receivers. Reference [8] uses more complex techniques like selective MAP detection for Turbo iterations. The purpose of this paper is to evaluate the performance of a technique with reasonable complexity for equalization and interference cancellation/suppression in OFDM based systems.

The main contribution of this work is a collection of error performance results presented in Section IV, which demonstrate the effectiveness of the Turbo DFE structure proposed in Sections II and III and suggest some design strategies and choice of parameters. Some of the major findings in this work are summarized in the following.

First, Turbo iterations significantly improve the overall error performance and typically 5 iterations yield sufficiently good results. Moreover, the lack of knowledge about the out-of-cell interferers' pilots degrades the performance significantly (e.g., about 5 dB for QPSK modulation at a bit-error-rate (BER) of 0.01). Since the interferer's pilot is not available, estimating the multiple-input multiple-output (MIMO) channel is difficult and it is found that directly estimating the coefficients of the feedforward and feedback filters of the DFE leads to better performance. Finally, the performance is quite sensitive to the number of training symbols when multiple antennas are used to transmit independent information streams.

The remainder of the paper is organized as follows. The channel model and the transmitter are introduced in Section II. The Turbo DFE receiver structure is described in Section III. Numerical results of this study are presented in Section IV before conclusions are drawn in Section V.

## II. CHANNEL MODEL AND TRANSMITTER

Consider the downlink of an OFDM system where each receiver has  $r$  antennas, and each base station is equipped with one or two transmit antennas. Assume that sufficient guard time is applied so that there is no intersymbol interference. Suppose the receiver of interest is located at the boundary between two cells, which not only receives the signal from

the desired base station, but also interference of up to equal strength from a different base station transmitting to a user in the neighboring cell.

At any OFDM symbol interval  $i$ , the received signal on an arbitrary subcarrier can be expressed as

$$\mathbf{y}(i) = \mathbf{H}_1 \mathbf{x}_1(i) + \mathbf{H}_2 \mathbf{x}_2(i) + \mathbf{n}(i) \quad (1)$$

$$= \mathbf{H} \mathbf{x}(i) + \mathbf{n}(i). \quad (2)$$

Here,  $\mathbf{H}_k$  is the  $r \times t$  dimensional channel matrix from the  $k$ -th base station to a particular mobile, where  $t = 1$  or  $2$  is the number of transmit antennas at each base station. Correspondingly,  $\mathbf{x}_k(i)$  is the  $t \times 1$  dimensional vector of transmitted symbols. The signal strength is incorporated into  $\mathbf{H}_k$ , and the entries of  $\mathbf{x}_k$  have unit variance. The notation is further simplified by stacking the matrices and vectors for the two users into  $\mathbf{H}$  and  $\mathbf{x}(i)$ , respectively. However, if the pilot of base station 2 is not known then the signal  $\mathbf{H}_2 \mathbf{x}_2(i)$  is treated as additional noise (i.e., enhancement of  $\mathbf{n}(i)$ ) and  $\mathbf{x}(i) = \mathbf{x}_1(i)$ . We assume that the channel across Tx-Rx antennas pairs and subchannels are independent flat Rayleigh fading (for each subchannel) so that  $\mathbf{H}_1$  and  $\mathbf{H}_2$  contain independent identically distributed circularly symmetric complex Gaussian entries. Block fading is assumed so that the fading coefficients remain static within each block (a block consists of several OFDM symbols), and vary independently from one block to another. Coded bits are interleaved and spread so that a codeword spans several blocks. As shown in Figure 1, the symbol detection is done independently on each sub-carrier and then the soft estimate of the coded bits is collected across subcarriers and blocks for de-interleaving and inclusion into the Turbo loop. The Tx-Rx structure of Figure 1 is further explained below. Also,  $\mathbf{n}$  is an  $r \times 1$  vector with unit-variance circularly symmetric complex Gaussian entries.

Consider the transmitter structure shown in Figure 1. A block of information bits from base station  $k$ , denoted by  $\{b_k(j)\}$ , is convolutionally encoded using a standard rate-1/2 convolutional code with constraint length 7 and the coded bits are then randomly permuted (interleaved). Further, Gray mapping is performed when the coded interleaved bits  $\{d_k(j)\}$  are input to a phase shift keying (PSK) modulator (here, we consider both QPSK and 8-PSK). To compose the packet (codeword) to be transmitted in a channel, we spread the symbol stream over all OFDM subchannels and transmit antennas, i.e., the antennas are used for multiplexing purpose only.<sup>1</sup> Further, the length of a packet spans several independently fading blocks. Finally, three known symbols are appended to both the beginning and the end of the packet to obtain the symbol sequence. Standard techniques are used to modulate the symbols onto orthogonal subcarriers for transmission which effectively convert the channel to an OFDM channel.

Since each subchannel is subject to unknown fading, the base station sends training symbols in every fading block on

<sup>1</sup>Multiple antennas can be in principle used for any achievable diversity-multiplexing tradeoff. In this work, however, we are most interested in multiplexing in order to maximize the data rate.

each subchannel to assist with channel estimation. Without loss of generality, we assume that training symbols precede data symbols in each block.

In the case of two base stations, two transmitters operate independently over the same frequency band. Thus the two OFDM symbol sequences are added at the receiver. Due to various practical reasons, the position and value of the pilot symbols sent by each base station are likely to be unknown to any out-of-cell receiver.

### III. TURBO DFE RECEIVER

#### A. Iterative Detection and Decoding

The block diagram of the Turbo DFE receiver is shown in Figure 1. The rationale behind the decision-feedback structure for multiuser communication is that if the intermediate estimates of some of the symbols can be obtained, the interference caused by those symbols can be reconstructed and canceled, which benefits detection of the remaining symbols. In particular, one may apply a pair of feedforward and feedback filters together with a decision function, as is shown in Figure 1.

In the  $m$ -th iteration of the Turbo-equalization algorithm, the received sequence  $\mathbf{y}(i)$  is the input to a symbol-spaced DFE that consists of a feedforward filter  $\mathbf{F}^{(m)}$  and a feedback filter  $\mathbf{B}^{(m)}$ . We show how these filters are obtained in Section III-B. The superscript  $m$  denotes the iteration number, so that for the first iteration  $m = 1$ . At time  $i$ , the output of the DFE for the  $m$ -th iteration is,

$$\mathbf{z}^{(m)}(i) = \mathbf{F}^{(m)} \mathbf{y}(i) - \mathbf{B}^{(m)} \hat{\mathbf{x}}^{(m)}(i) \quad (3)$$

where the input to the feedback filter,  $\hat{\mathbf{x}}^{(m)}(i)$ , contains soft decisions of the corresponding transmitted symbols. For  $m > 1$ , these values are computed by the MAP decoder at iteration  $m - 1$ .

For  $m = 1$ , each  $\hat{\mathbf{x}}^{(1)}(i)$  is computed directly from the corresponding DFE output  $\mathbf{z}^{(1)}(i)$  (output of  $\mathbf{F}^{(1)}$ , and used to cancel interference associated with the interfering antenna in a successive manner. The DFE outputs  $\{\mathbf{z}^{(1)}(i)\}$  are buffered and used to compute the *a priori* probabilities. These probabilities are de-interleaved and fed into a MAP decoder that produces the *a posteriori* probabilities of the coded bits. This completes the first iteration.

In subsequent iterations, the outputs of the MAP decoder are re-interleaved, and used to compute soft symbol estimates. The symbol estimates are fed to the DFE. The filters are updated in every iteration based on the time-varying *a posteriori* probabilities, but remain constant for the duration of a block. In the final iteration, the MAP decoder outputs hard decisions for the information sequence. The reader is referred to [1] for the detailed description of a similar receiver in a different context.

In case each base station has multiple antennas transmitting separate streams of information, each stream of information bits is recovered by processing the received signal using the DFE in order to cancel the interference from all interfering transmit antennas including those of the desired base station.

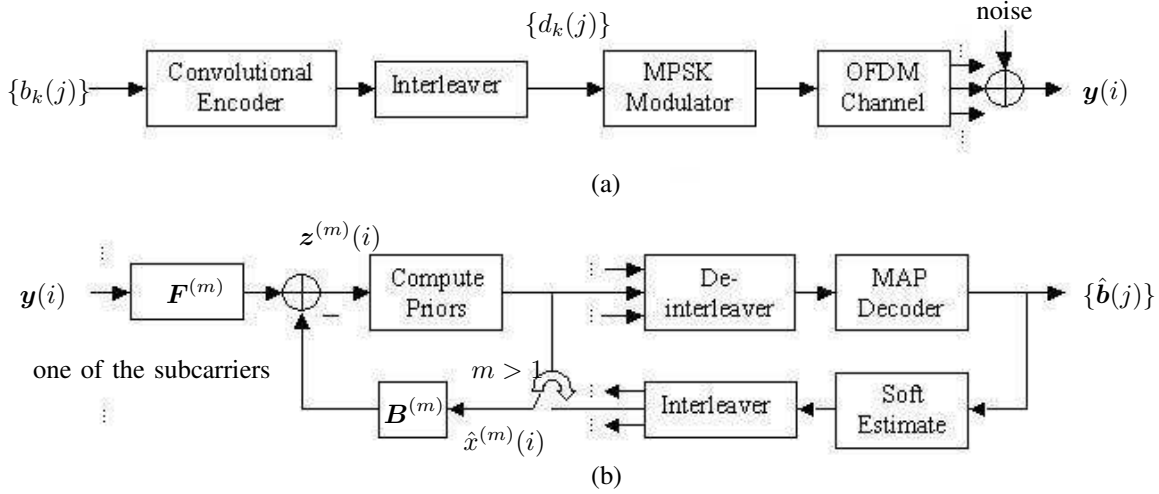

Fig. 1. Block diagram of (a) The transmitter for user  $k$  and the OFDM channel, and (b) The Turbo DFE receiver, where the decision-feedback filtering for one subcarrier is shown to the left and the joint decoder and interleavers are shown to the right.

### B. Training-based Filter Coefficient Estimation

Two training-based schemes for producing the feedforward and feedback filters are considered: 1) direct estimation of the filter coefficients, and 2) least-square estimation of channel coefficients which are then used to compute the filters. It is found through simulation that the first scheme is superior (see Section IV). Hence we only describe the algorithm for directly estimating the filter coefficients to conserve space.

The coefficients of both the feedforward filter and feedback filter at  $m$ -th iteration, namely  $\mathbf{F}^{(m)}$  and  $\mathbf{B}^{(m)}$ , are estimated by minimizing the cost function

$$\sum_{i=1}^T \left\| \hat{\mathbf{x}}^{(m)}(i) - \left( \mathbf{F}^{(m)} \right)^\dagger \mathbf{y}(i) + \left( \mathbf{B}^{(m)} \right)^\dagger \hat{\mathbf{x}}^{(m)}(i) \right\|^2 \quad (4)$$

where  $\hat{\mathbf{x}}^{(m)}(i)$  denotes the soft estimate for the vector  $\mathbf{x}(i)$  at  $m$ -th iteration. Note that here  $T$  denotes total block length including training and data symbols. Corresponding to the  $l$ -th element of  $\mathbf{x}(i)$ , let  $\mathbf{F}_l^{(m)}$  denote the  $l$ -th column of  $\mathbf{F}^{(m)}$  and  $\check{\mathbf{B}}_l^{(m)}$  denote the  $l$ -th column of  $\mathbf{B}^{(m)}$  with its  $l$ -th element deleted. Further, let  $\mathbf{s}_{-l}(i) = \begin{bmatrix} \mathbf{y}(i) \\ \check{\mathbf{x}}_{-l}^{(m)}(i) \end{bmatrix}$  where  $\check{\mathbf{x}}_{-l}^{(m)}(i)$  contains the elements of  $\hat{\mathbf{x}}^{(m)}(i)$  with its  $l$ -th element, say  $\hat{x}_{(l)}^{(m)}(i)$ , deleted. The non-causal DFE can now be expressed as [1],

$$\begin{bmatrix} \mathbf{F}_l^{(m)} \\ -\check{\mathbf{B}}_l^{(m)} \end{bmatrix} = \mathbf{R}_{ss}^{-1} \mathbf{R}_{sx} \quad (5)$$

where

$$\mathbf{R}_{ss} = \sum_{i=1}^T \mathbf{s}_{-l}(i) \mathbf{s}_{-l}^\dagger(i) \quad (6)$$

$$\mathbf{R}_{sx} = \sum_{i=1}^T \mathbf{s}_{-l}(i) \left( \hat{\mathbf{x}}_{(l)}^{(m)}(i) \right)^* \quad (7)$$

Another advantage of this approach over the channel estimation approach is that it does not rely on the perfect feedback assumption to calculate the feed-back filter. Note that for the first iteration ( $m = 1$ ), only training bits are used for computation in (4) and  $\mathbf{z}^{(1)}(i)$  in (3) is computed using a causal DFE (successive cancellation).

## IV. RESULTS OF NUMERICAL STUDY

The performance of the Turbo DFE receiver for downlink OFDM is studied via simulation. Due to limited space, we present numerical evidence that demonstrates some of the key results, while the remaining results are described in text. In all experiments, we assume a dual-antenna receiver and rate-1/2 convolutional code with no puncturing. Here SNR represents the ratio of energy per bit and the noise variance ( $E_b/N_0$ ).

If nothing is specified about the training length, then it is assumed that 26 antipodal symbols are transmitted through each antenna per block. Two training-based schemes for producing the feedforward and feedback filters are compared: 1) direct estimation of the filter coefficients, and 2) least-square estimation of channel coefficients, which are then used to compute the filters. If the interfering users' pilots are known to the receiver, then numerical results suggest that the two training schemes perform almost identically. If the interfering pilots are not available to the receiver, then it is found that direct estimation of the filters is superior. This is because the channel coefficients of the interfering user cannot be estimated easily, whereas directly estimating the filter coefficients inherently suppresses the interference. In all subsequent numerical results, the filter coefficients are estimated directly and updated in every Turbo iteration from the most current soft symbol estimates.

In order to achieve diversity gain, the coded and interleaved symbols are spread over all the OFDM subchannels, the benefit of which has been verified through simulation (omitted here due to space limit). The packet length in symbols is

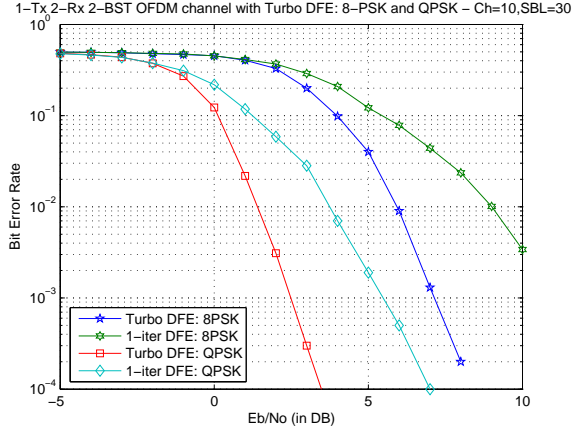

Fig. 2. BER versus  $E_b/N_0$  in an OFDM channel for 1-iteration DFE and 5-iteration Turbo DFE. There is 1 user with 2 receive antennas and 2 base stations each with 1 transmit antenna. SBL: symbol block length.

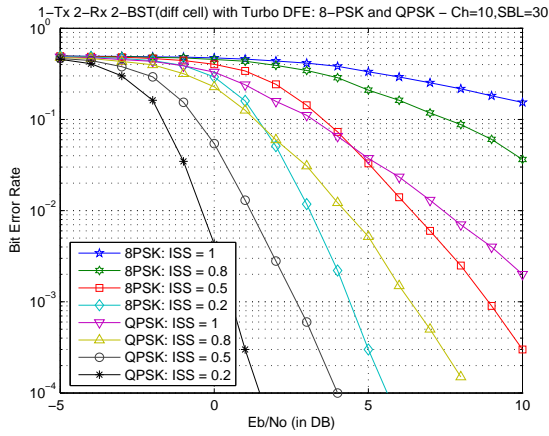

Fig. 3. BER versus  $E_b/N_0$  for Turbo DFE in OFDM channel. There is 1 user with 2 receive antennas and 2 base stations each with 1 transmit antenna. Plots are shown for different received signal strengths from the interfering base station (ISS: Interfering signal strength).

equal to the product of the number of blocks per packet, the symbol block length (SBL), the number of transmit antennas and the number of subchannels. The symbol block length is adjusted to keep the packet length constant. It is observed that increasing the number of subchannels beyond 10 does not provide much additional diversity gain. Therefore, for all subsequent numerical simulations, unless otherwise noted, we assume 10 subchannels, 4 blocks and a symbol block length of 30.

Figure 2 shows the performance gain achieved by using a Turbo DFE compared to a non-Turbo DFE in a two-cell model assuming that the receiver has access to the interfering pilots. It is observed that at an error rate of  $10^{-3}$ , 5 Turbo iterations achieve more than 3 dB gain for both QPSK and 8-PSK modulations.

In the following, we make the model more realistic and drop the assumption that the pilots from the interfering base

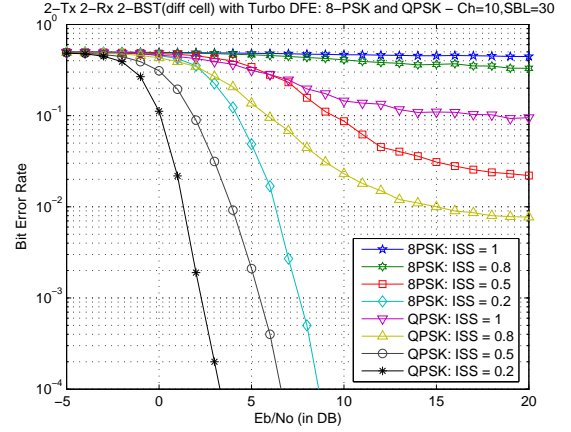

Fig. 4. BER versus  $E_b/N_0$  for a Turbo DFE in an OFDM channel. There is 1 user with 2 receive antennas and 2 base stations each with 2 transmit antennas. Plots are shown for different received signal strengths from the interfering base station (ISS: the ratio between the strength of the interfering signal and the desired signal).

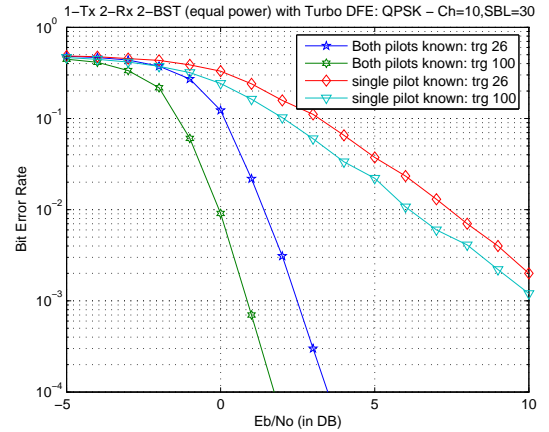

Fig. 5. BER versus  $E_b/N_0$  for a Turbo DFE in an OFDM channel for QPSK modulation. There is 1 user with 2 receive antennas and 2 base stations each with 1 transmit antenna. Plots are shown assuming a) interfering pilots are available to the user and b) interfering pilots are not available to the user with different training lengths.

station are available. Figure 3 shows the error rate performance for both 8-PSK and QPSK modulations in the two-cell model for different interfering signal strengths. It is clearly seen that as the strength of the interfering signal decreases, the error performance improves.

In Figure 4, we plot the error rate performance in the same setting as in Figure 3 except that each base station has 2 transmit antennas. As a result of multiplexing, there are 3 interfering data streams and the order of receiver diversity is 2. An error floor is observed because of lack of degrees of freedom for interference cancellation.

Figure 5 shows the performance gain we can achieve if the receiver knows the pilots of the interfering base station. QPSK modulation scheme is assumed and performance for two different training lengths is shown. At an error rate of

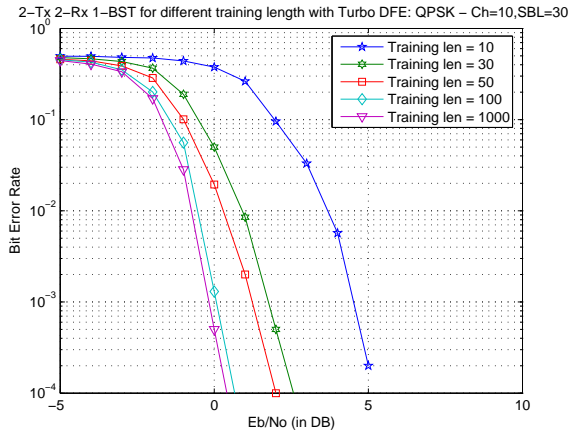

Fig. 6. BER versus  $E_b/N_0$  for a Turbo DFE in an OFDM channel for QPSK modulation. There is 1 user with 2 receive antennas and 1 base station with 2 transmit antennas. Plots are shown for different training lengths.

0.001 with a training length of 100, we lose 9 dB if the receiver does not know the interfering pilots.

Figure 6 shows the performance of the Turbo DFE for different training lengths in a single base station environment with QPSK modulation. It is interesting to note that the performance is very sensitive to training length with multiple transmit antennas. It takes a large number of training symbols to converge to the performance with perfect channel knowledge. If we increase training length from 10 to 50, the performance gain is about 3 dB at an error rate of 0.1 or smaller. When multiple transmit antennas are used, the Turbo DFE performance becomes very sensitive to training length. The sensitivity can be attributed to interference among pilots from interfering transmit antennas. Since we are splitting the coded bits across transmit antennas instead of transmitting the same coded bits through them, pilots from different transmit antennas interfere with one another and thus degrade the filter coefficient estimates. This argument has been confirmed by removing the interfering antennas and finding that the performance becomes insensitive to training length.

Figure 7 shows satisfactory error performance in the multiple base station scenario with QPSK, assuming that the interfering pilots are not available. In contrast to Figure 6, we note that there is a significant performance gain if we can extract some information about the interfering pilots and hence the interference instead of treating the interference as noise.

## V. CONCLUSION

We have studied the performance of a Turbo DFE receiver in a downlink OFDM channel. We focus on a worst case scenario where the desired user is at the cell boundary and subject to an equally strong interference from a neighboring cell. The Turbo DFE receiver, which is equipped with multiple antennas and exploits channel diversity, exhibits good performance in Rayleigh fading. We observe that performance with multiple transmit antennas at the base station is sensitive to training length and that a relatively large number of training symbols

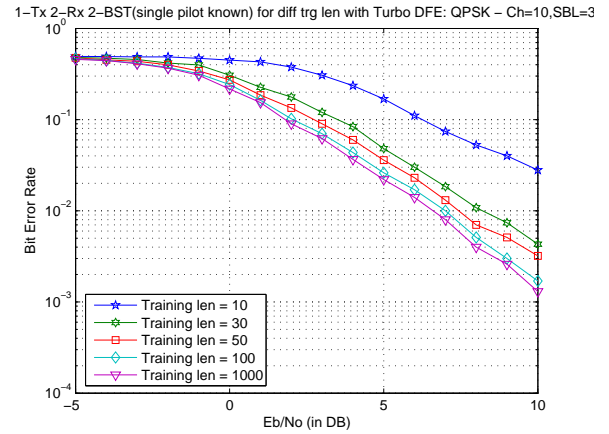

Fig. 7. BER versus  $E_b/N_0$  for Turbo DFE in OFDM channel for QPSK modulation. There is 1 user with 2 receive antennas and 2 base stations each with 1 transmit antenna. Plots are shown for different training lengths. Assumption: Interfering pilots are not available to the user.

are needed to achieve perfect channel knowledge performance. It is also evident from the numerical study that the lack of knowledge about interfering pilots takes a significant toll on the error performance. It is therefore of interest to extract some information about the interferer's pilots instead of treating it as noise.

## REFERENCES

- [1] Yakun Sun, V. Tripathi and M.L. Honig, "Adaptive turbo reduced-rank equalization for MIMO channels," *IEEE Trans. Wireless Commun.*, vol. 4, No. 6, Nov. 2005, pp. 2789- 2800.
- [2] C. Laot, A. Glavieux and J. Labat, "Turbo equalization: Adaptive equalization and channel decoding jointly optimized," *IEEE J. Sel. Areas Commun.*, vol. 19, No. 9, Sep. 2001, pp. 1744-1752.
- [3] M. Tuchler, R. Koetter and A. C. Singer, "Turbo equalization: principles and new results," *IEEE Transactions on Communications*, vol. 50, No. 5, May 2002, pp.754-767
- [4] G. Bauch and N. Al-Dhahir, "Reduced-complexity space time turbo equalization for frequency-selective MIMO channels," *IEEE Trans. Wireless Commun.*, vol. 1, No. 4, Oct. 2002, pp. 819-828.
- [5] T. Abe and T. Matsumoto, "Space-time turbo equalization in frequency-selective MIMO channels," *IEEE Transactions on Vehicular Technology*, vol. 52, No. 3, May 2003, pp.469-475.
- [6] D. Zuyderhoff, X. Wautelet, A. Dejonghe and L. Vandendorpe, "MMSE Turbo Receiver for space-frequency bit-interleaved coded OFDM," in *Proc. IEEE VTC Fall*, 2003.
- [7] A. Wolfgang, S. Chen and L. Hanzo, "Decision Feedback Aided Bayesian Turbo Space-Time Equalizer for Parallel Interference Cancellation in SDMA Systems," in *Proc. IEEE VTC Fall*, 2005.
- [8] X. Zhuang and F. W. Vook, "Coding-assisted MIMO joint detection and decoding in turbo-coded OFDM," in *Proc. IEEE VTC Fall*, 2002.
- [9] D. Tujkovic, M. Juntti, and M. Latve-aho, "Space-frequency turbo coded OFDM," in *Proc. IEEE GLOBECOM*, San Antonio, Vol. 2, pp. 876-880, Nov. 2001.
- [10] I. Fijalkow, A. Roumy, S. Ronger, D. Pirez and P. Vila, "Improved interference cancellation for turbo equalization," in *Proc. Int. Conf. Acoustics, Speech and Signal Processing*, Istanbul, Turkey, May 2000, Vol. 1, pp. 416-419.
- [11] G. Woodward, R. Ratasuk, M. L. Honig and P. Rapajic, "Minimum mean-squared error multiuser decision-feedback detectors for DS-CDMA," *IEEE Trans. on Communications*, vol. 50, pp. 2104-2112, Dec 2002.