



N O R T H W E S T E R N  
U N I V E R S I T Y

MSIT | Master of Science in Information Technology

---

# MSIT 413: Wireless Technologies

## *Week 3*

*Michael L. Honig*  
*Department of EECS*  
*Northwestern University*

*October 2017*



# Why Study Radio Propagation?

- To determine **coverage**

Can we use the same channels?

- Must determine **path loss**

– Function of

- Frequency
- Distance
- Terrain (office building, urban, hilly, rural, etc.)

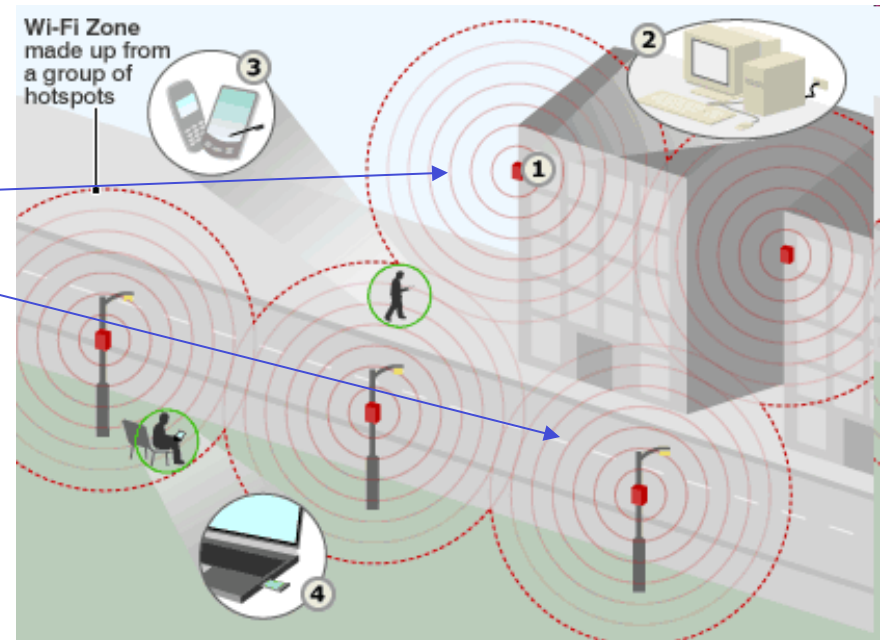

Need “large-scale” models



# Why Study Radio Propagation?





# Why Study Radio Propagation?

- To enable **robust** communications

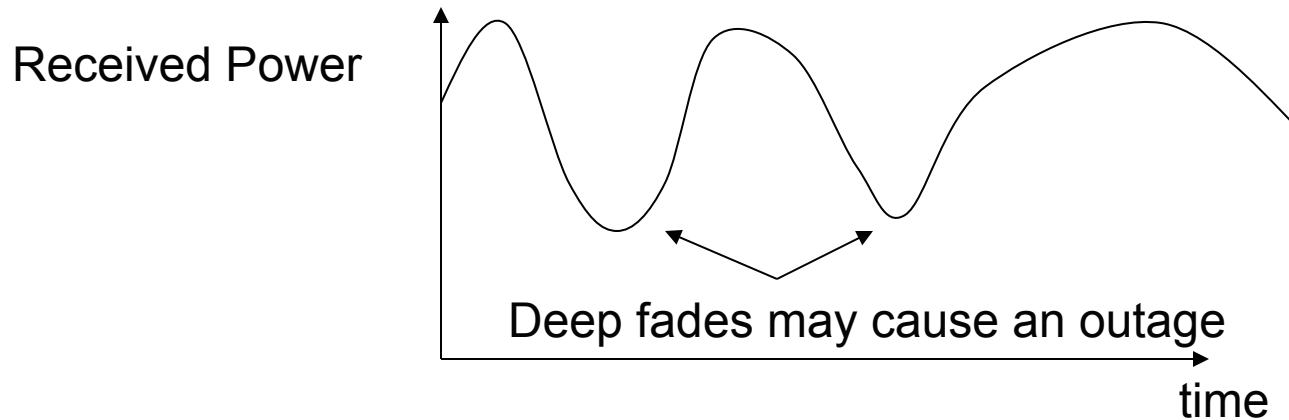

- How can we guarantee reliable communications?
- What data rate can we provide?
- Must determine **signal statistics**:
  - Probability of outage
  - Duration of outage

Need “small-scale” models



## Will provide answers to...

- What are the major causes of attenuation and fading?
- Why does the achievable data rate decrease with mobility?
- Why are wireless systems evolving to wider bandwidths (spread spectrum and OFDM)?
- Why does the accuracy of location tracking methods increase with wider bandwidths?



# Propagation Key Words

- Large-scale effects
  - Path-loss exponent
  - Shadow fading
- Small-scale effects
  - Rayleigh fading
  - Doppler shift and Doppler spectrum
  - Coherence time / fast vs slow fading
- Narrowband vs wideband signals
- Multipath delay spread and coherence bandwidth
- Frequency-selective fading and frequency diversity



# Propagation Mechanisms: 1. Free Space

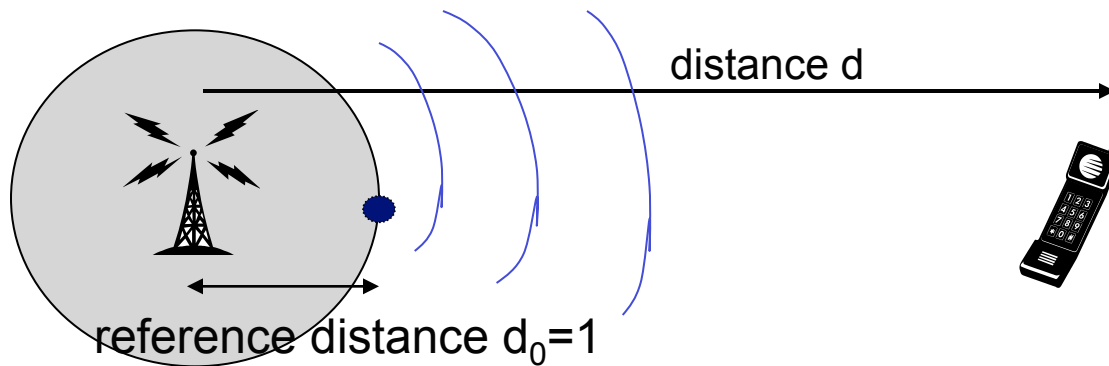

Received power  $P_r \approx P_0 \left( \frac{d}{d_0} \right)^{-n}$

Reference power at reference distance  $d_0$

Path loss exponent = 2

In dB:  $P_r = P_0 \text{ (dB)} - 20 \log (d)$

$$P_0 = G_t G_r \left( \frac{\lambda}{4\pi} \right)^2$$

↑ antenna gains      ↑ wavelength

$P_r \text{ (dB)}$

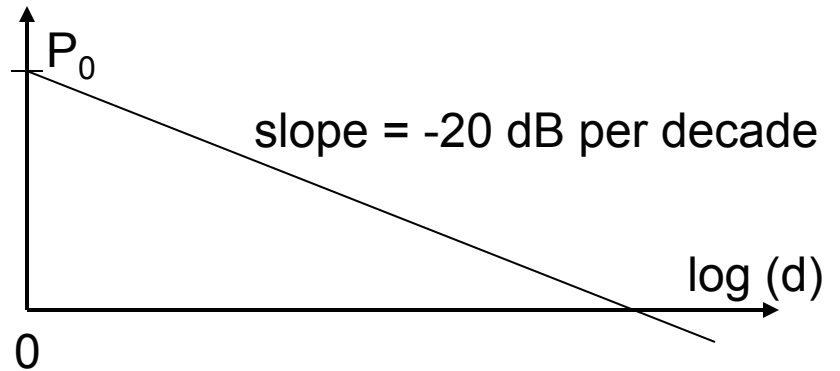



# Wavelength

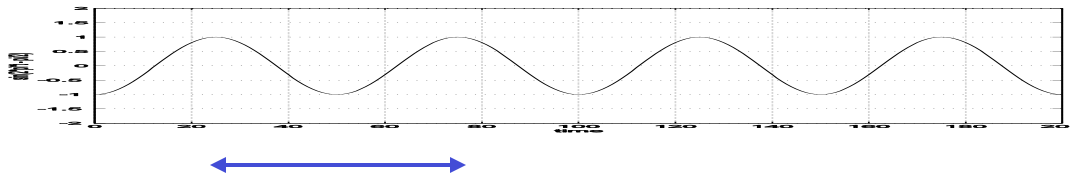
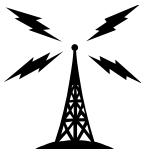

$$\lambda \text{ (meters)} = c \text{ (speed of light)} / \text{frequency}$$

- Wavelength  $\gg$  size of object  $\rightarrow$  signal penetrates object.
- Wavelength  $\ll$  size of object  $\rightarrow$  signal is absorbed and/or reflected by object.
- **Large-scale effects** refers to propagation over distances of many wavelengths.

**Small-scale effects** refers to propagation over a distances of a fraction of a wavelength.



# Dipole Antenna

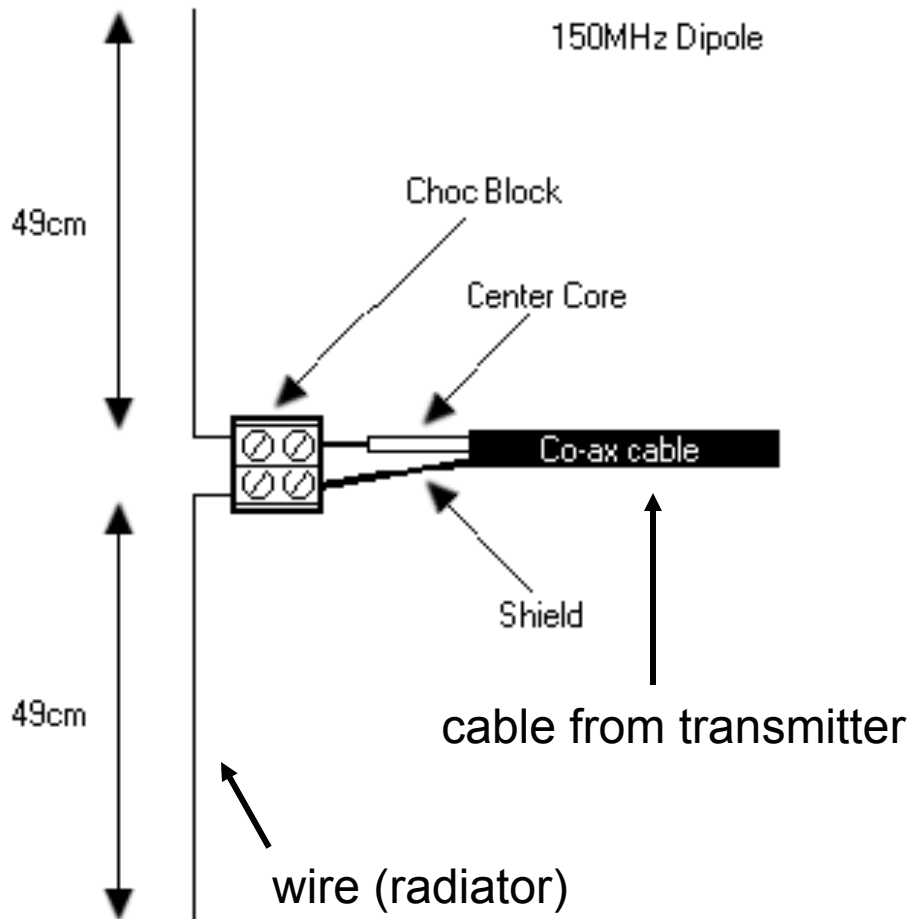

802.11 dipole antenna



# Radiation Pattern: Dipole Antenna

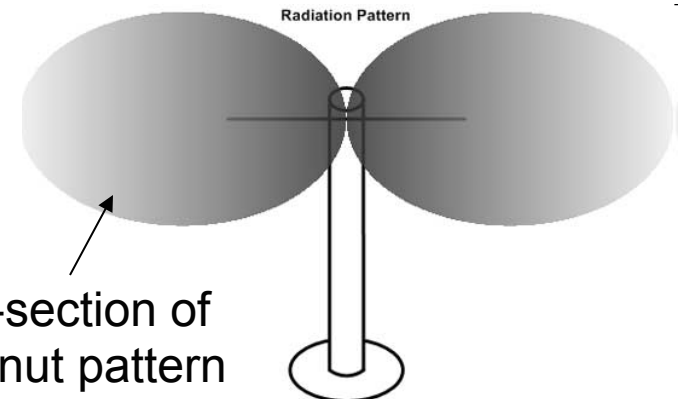
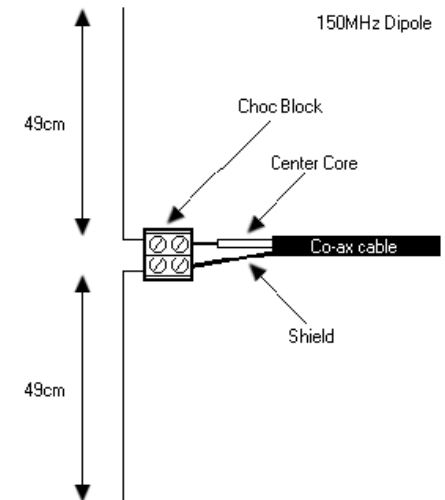
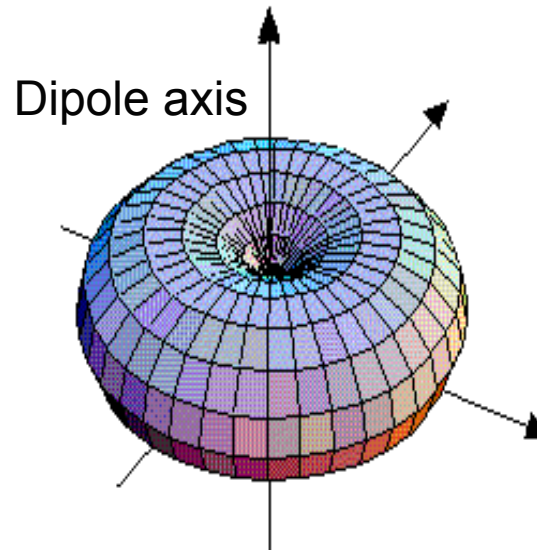
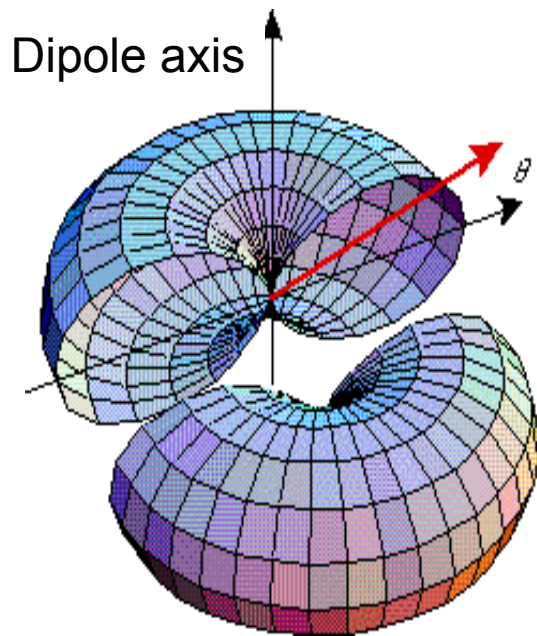

Electromagnetic wave radiates out from the dipole axis.



# Antenna Gain Pattern

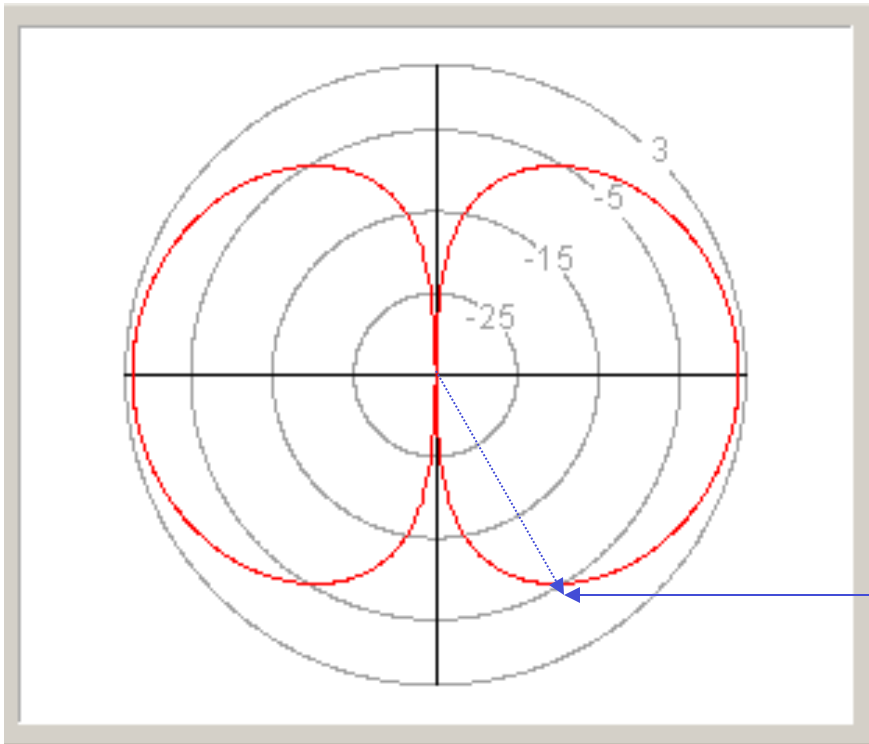

Red curve shows the antenna gain versus angle relative to an isotropic pattern (perfect circle) in dB.

Often referred to as dBi, dB “isotropic”.

-5 dB (factor of about 1/3) relative to isotropic pattern

Dipole pattern (close to isotropic)



# Antenna Gain Pattern

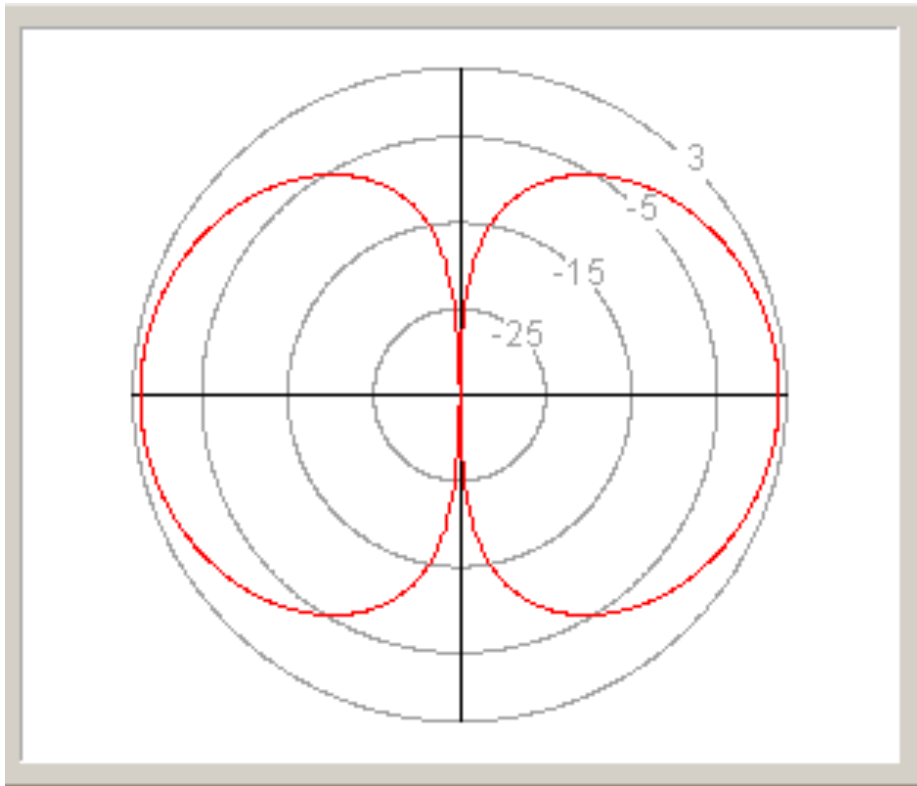

Dipole pattern (vertical)

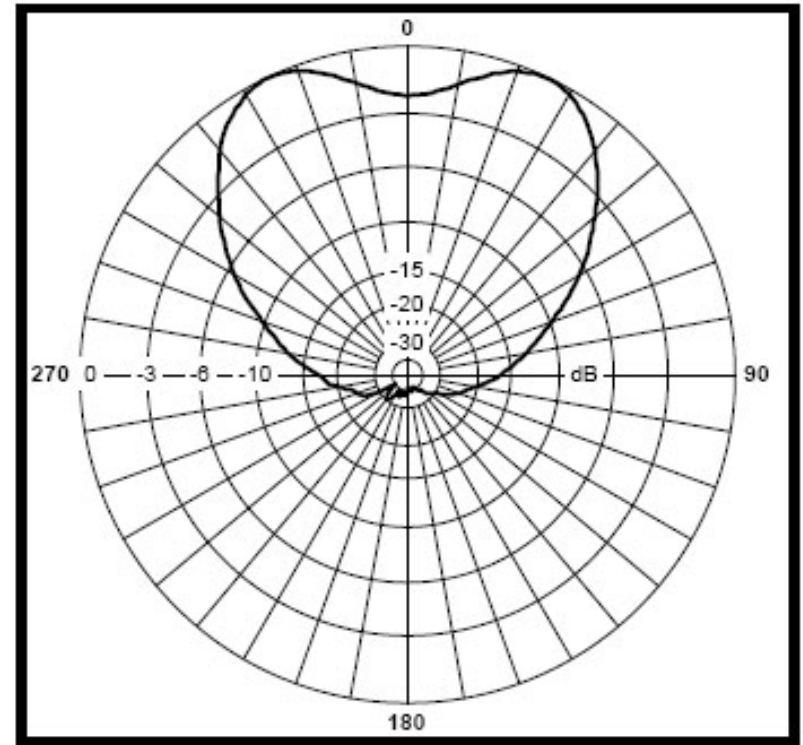

90 degree sector (from above)



# Attenuation: Wireless vs. Wired

## Unshielded Twisted Pair

- Path loss ~ 13 dB / 100 m or 130 dB / 1 km
  - Increases linearly with distance
- Requires repeaters for long distances

## 1 GHz Radio (free space)

- Path loss ~ 30 dB for the first meter + 20 dB / decade
  - 70 dB / 100 meters (2 decades)
  - 90 dB / 1 km (3 decades)
  - 130 dB / 100 km!
  - Increases as **log** (distance)
- Repeaters are infeasible for satellites

Short distance → Wired has less path loss.  
Large distance → Wireless has less path loss.



# Propagation Mechanisms

## 2. Reflection

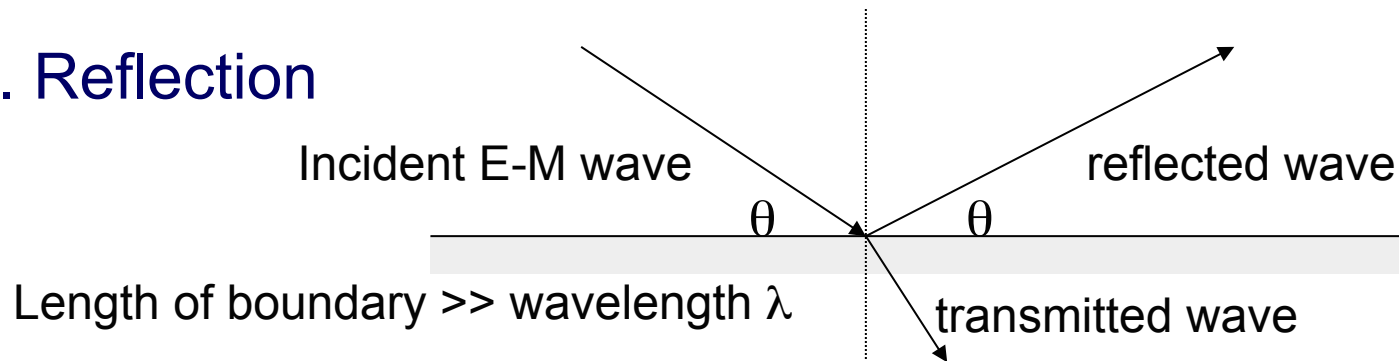

## 3. Diffraction

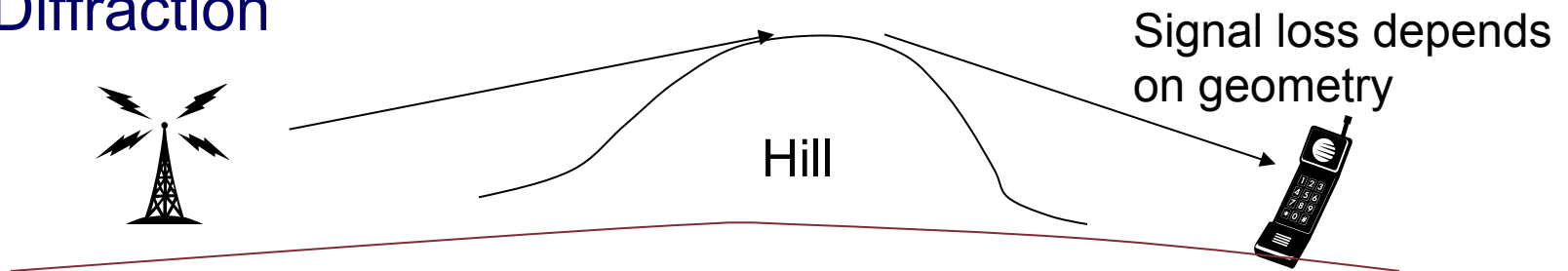

## 4. Scattering



# Why Use $> 500$ MHz?



## Why Use $> 500$ MHz?

- There is more spectrum available above 500 MHz.
- Lower frequencies require larger antennas
  - Antenna dimension is on the order of a wavelength = (speed of light/frequency)  
= 0.6 M @ 500 MHz
- Path loss increases with frequency for the first meter
  - 10's of GHz: signals are confined locally
  - More than 60 GHz: attenuation is too large (oxygen absorbs signal)



# 700 MHz Auction

- Broadcast TV channels 52-69 relocated in Feb. 2009.
  - 6 MHz channels occupying 698 – 806 MHz
- Different bands were auctioned separately:
  - “A” and “B” bands: for exclusive use (like cellular bands)
  - “C” band (11 MHz): must support open handsets, software apps
  - “D” band (5 MHz): shared with public safety (has priority)
- Commenced January 24, 2008, ended in March

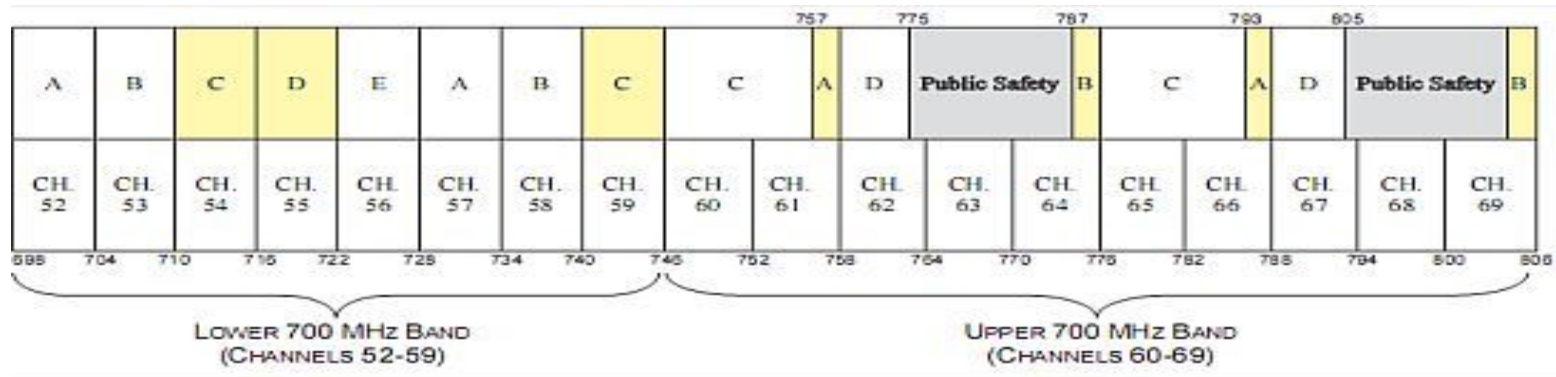



## Why all the Hubbub?

- This band has excellent propagation characteristics for cellular types of services (“beach-front property”).
- Rules for spectrum sharing can be redefined...

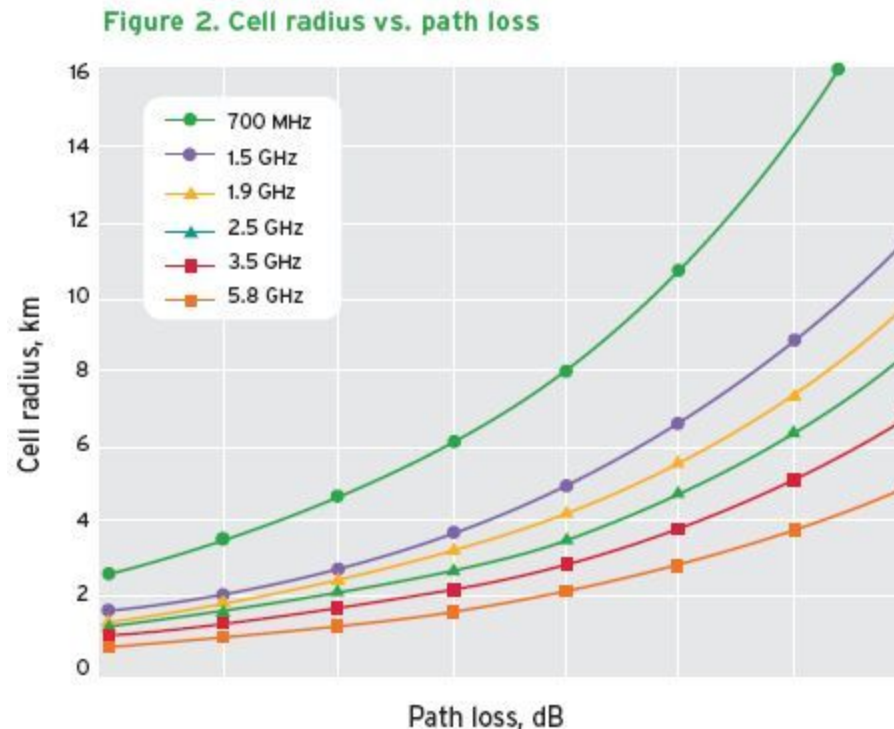



**700 MHz Offers the Only Affordable Network Solution in Sparsely Populated Areas**

	700 MHz Propagation	1900 MHz Propagation	2400 MHz Propagation
<b>Total Network cost @ \$150k/cell</b>	<b>\$150,000</b>	<b>\$600,000</b>	<b>\$1,500,000</b>
<b>Network Cost per Customer</b>	<b>\$180</b>	<b>\$725</b>	<b>\$1820</b>
<b># Mos. to Network Cost Breakeven</b>	<b>9 Months</b>	<b>36 Months</b>	<b>91 Months</b>

Cell Site Coverage per thousand square miles



**700 MHz Coverage**

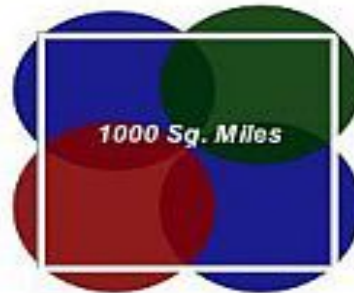

**1900 MHz Coverage**



**2400 MHz Coverage**



## C Band Debate

- Service providers in the U.S. did not allow any services, applications, or handsets from unauthorized 3<sup>rd</sup> party vendors.
- Google asked the FCC to stipulate that whoever wins the spectrum must support open applications, open devices, open services, open networks (net neutrality for wireless).
- Verizon wants to maintain “walled-garden”.
- FCC stipulated open applications and devices, but not open services and networks:  
*spectrum owner must allow devices or applications to connect to the network as long as they do not cause harm to the network*
- Aggressive build-out requirements:
  - *Significant coverage requirement in four years, which continues to grow throughout the 10-year term of the license.*



## Sold to...

- Verizon
- Other winners: AT&T (B block),  
Qualcomm (B, E blocks)
- Total revenue: \$19.6 B
  - \$9.6 B from Verizon, \$6.6 B from AT&T
- Implications for open access, competition?



## D Band Rules

- Winner gets to use both D band and adjacent public service band (additional 12 MHz!), but service can be preempted by public safety in emergencies.
- Winner must build out public safety network: must provide service to 75% of the population in 4 years, 95% in 7 years, 99.3% in 10 years
- Minimum bid: \$1.3 B; estimated cost to deploy network: \$10-12 B
- Any takers? ...



## D Band Rules

- Winner gets to use both D band and adjacent public service band (additional 12 MHz!), but service can be preempted by public safety in emergencies.
- Winner must build out public safety network: must provide service to 75% of the population in 4 years, 95% in 7 years, 99.3% in 10 years
- Minimum bid: \$1.3 B; estimated cost to deploy network: \$10-12 B
- Any takers? ... Nope! Highest bid was well below reserve...



# More Recent Auctions

- Advanced Wireless Services (AWS)-3 (2015)
  - \$44.8 B (far exceeded expectations)
  - 65 MHz total in 1.7, 2.1 GHz bands
  - Included 15 MHz of unpaired uplink spectrum
- 600 MHz incentive auctions
  - Repurposing broadcast TV spectrum via double auction.
  - Remaining TV stations to be “repacked” at lower frequencies.
  - Generated \$19.8 B for 70 MHz  
(T-Mobile, Dish, Comcast won most of the licenses.)



# Radio Channels

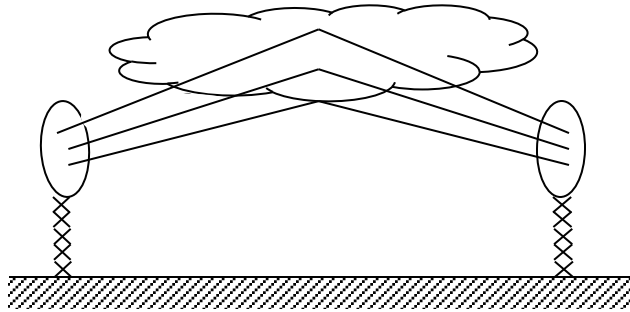

Troposcatter

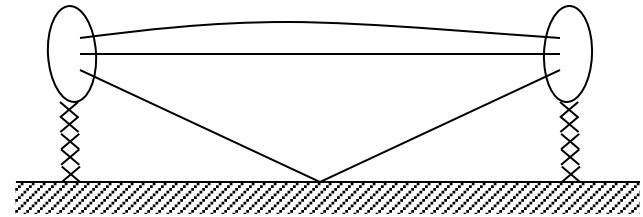

Microwave LOS

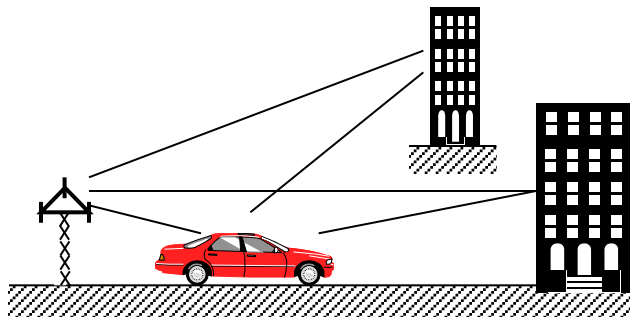

Mobile radio

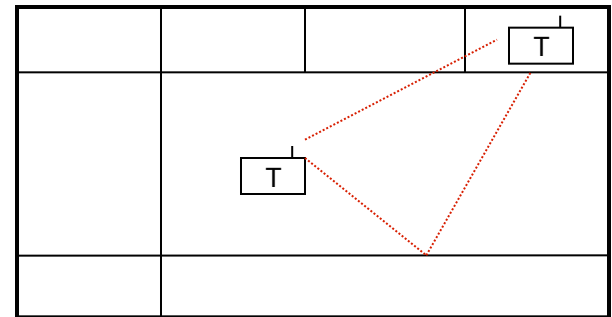

Indoor radio



# Sinusoidal Signal

Electromagnetic wave  $s(t) = A \sin (2 \pi f t + \theta)$

Amplitude  $A=1$

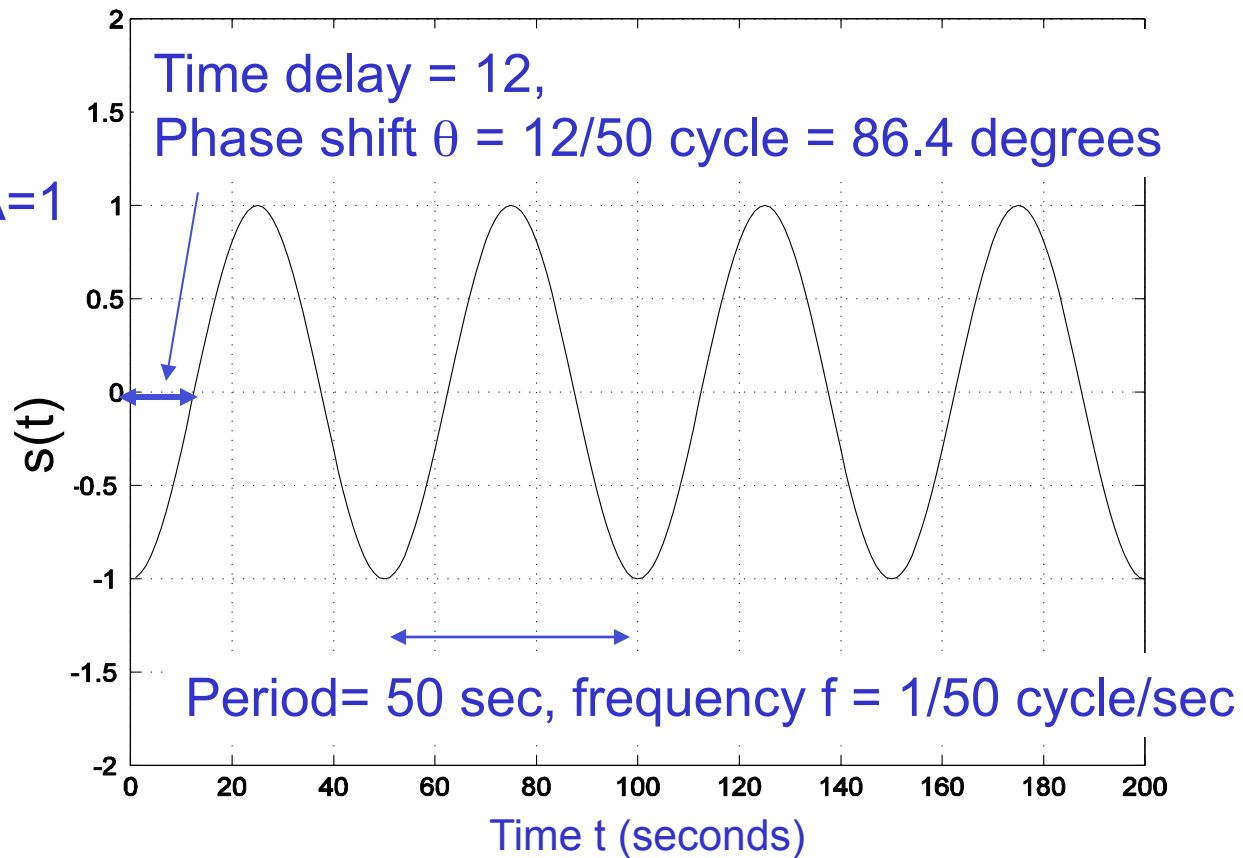



# Two Signal Paths

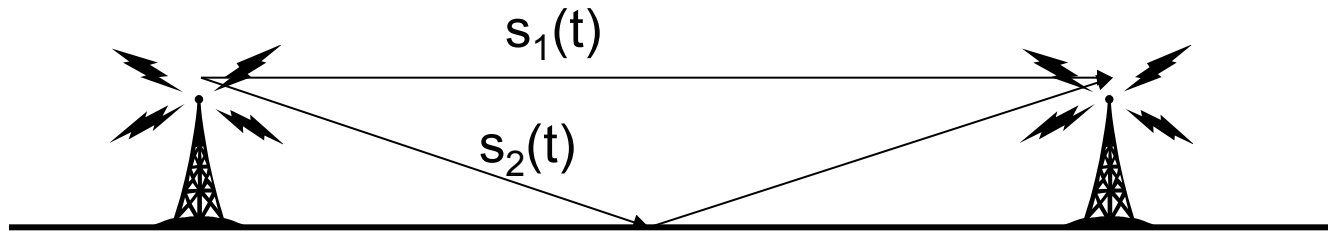

Received signal  $r(t) = s_1(t) + s_2(t)$

Suppose  $s_1(t) = \sin 2\pi f t$ .

Then  $s_2(t) = h s_1(t - \tau) = h \sin 2\pi f (t - \tau)$

↑  
attenuation  
(e.g.,  $h$  could be  $\frac{1}{2}$ )

↗  
delay  
(e.g.,  $\tau$  could be 1 microsec.)



# Sinusoid Addition (Constructive)

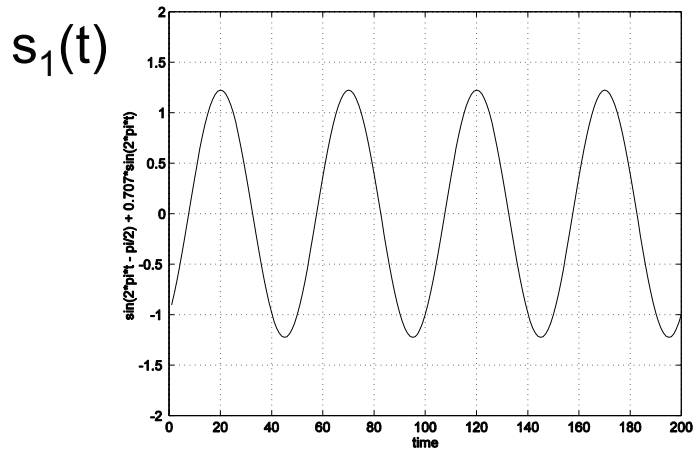

+

=

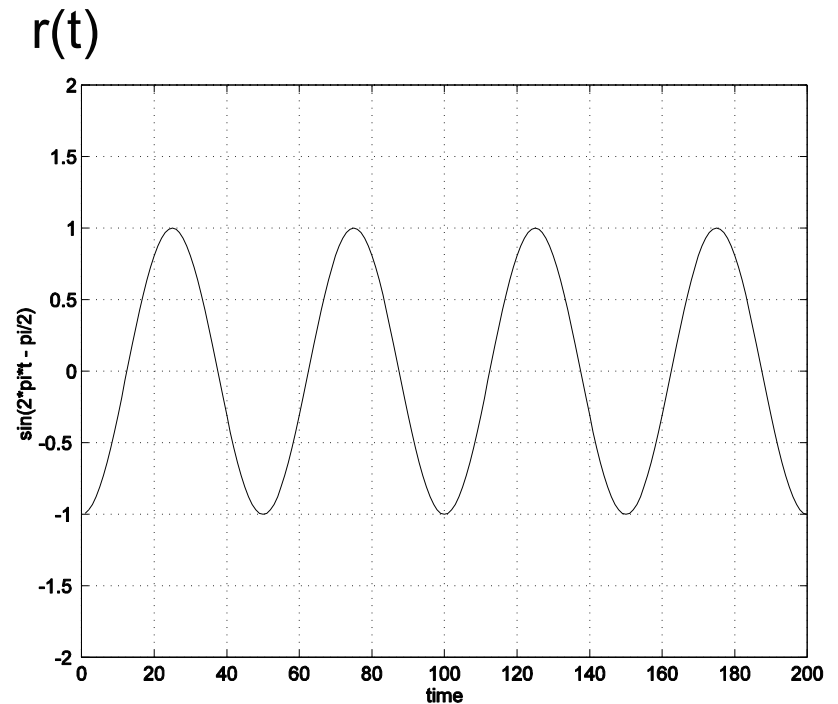
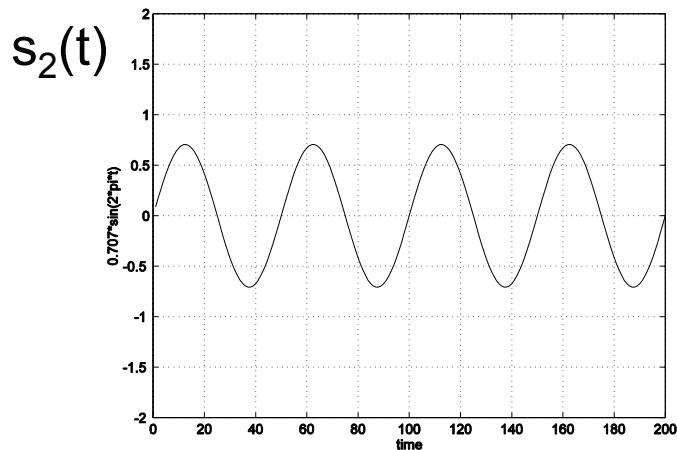

Adding two sinusoids with the same frequency gives another sinusoid with the same frequency!



# Sinusoid Addition (Destructive)

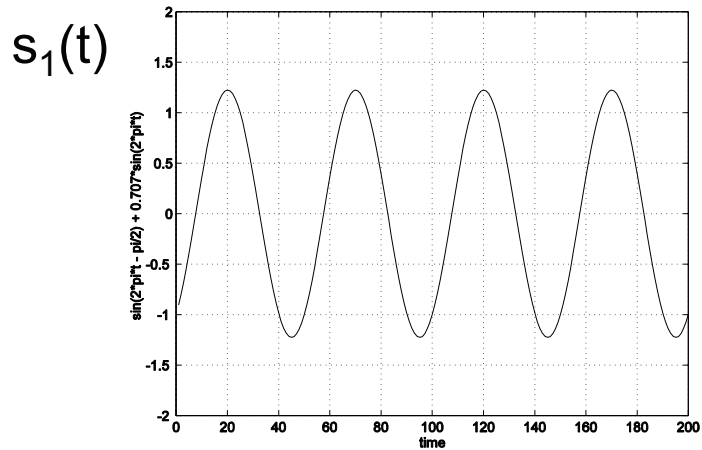

$s_2(t)$

+

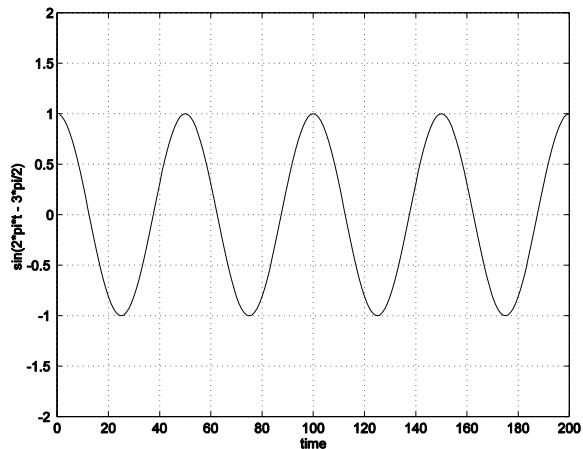

=

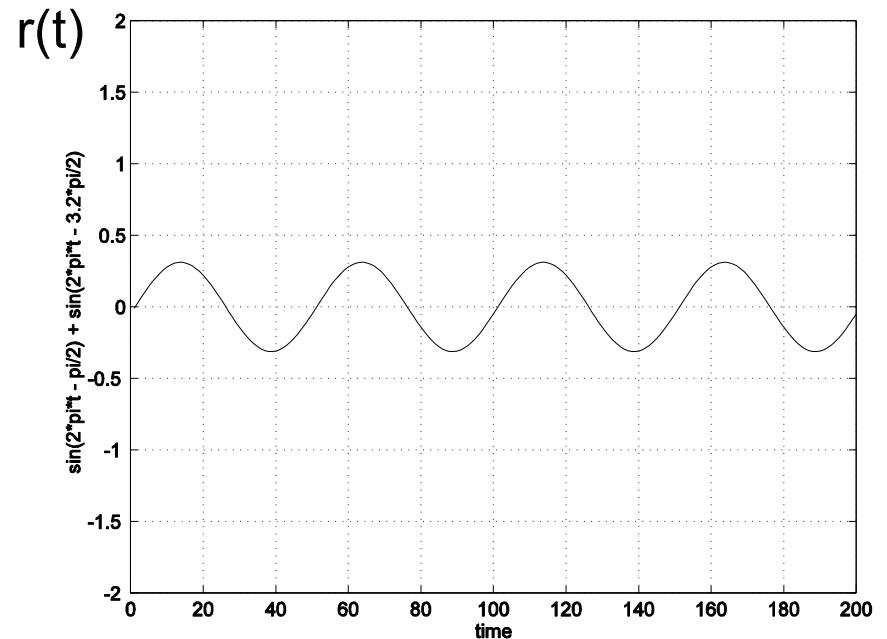

Signal is faded.



# Indoor Propagation Measurements

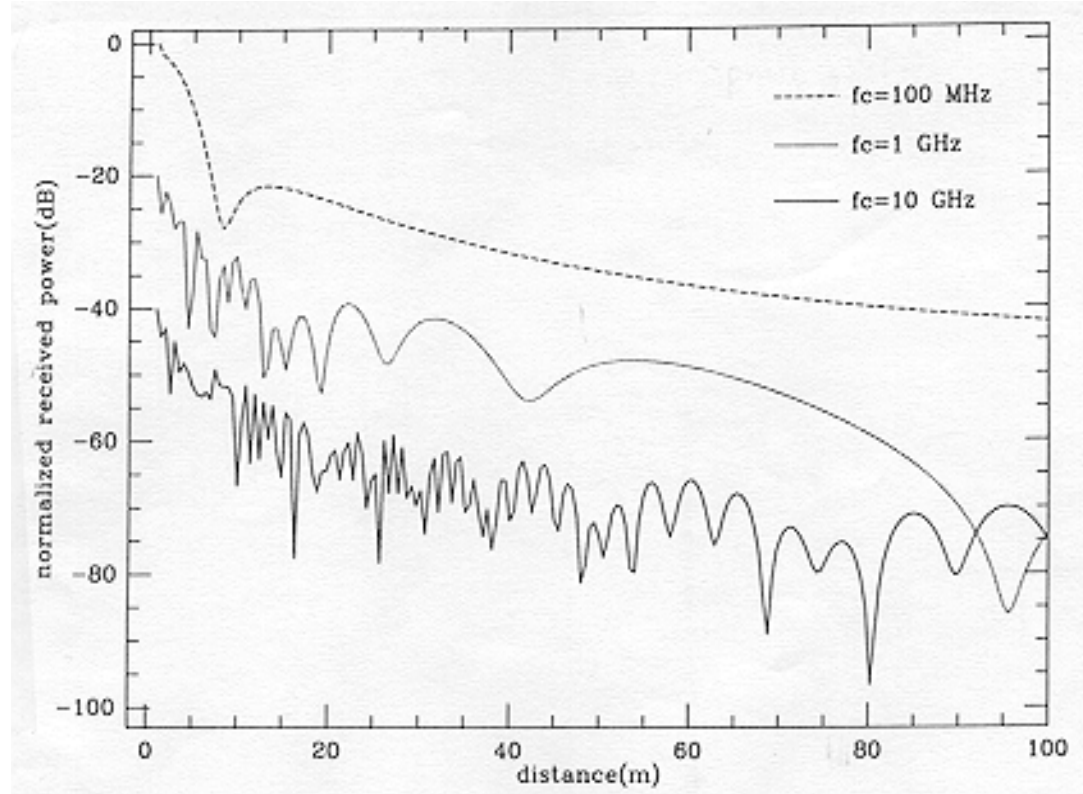
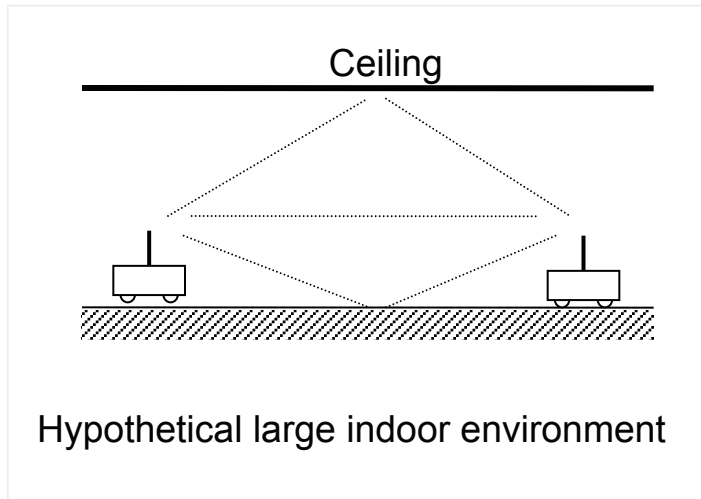

Normalized received power vs. distance



# Indoor Propagation Measurements

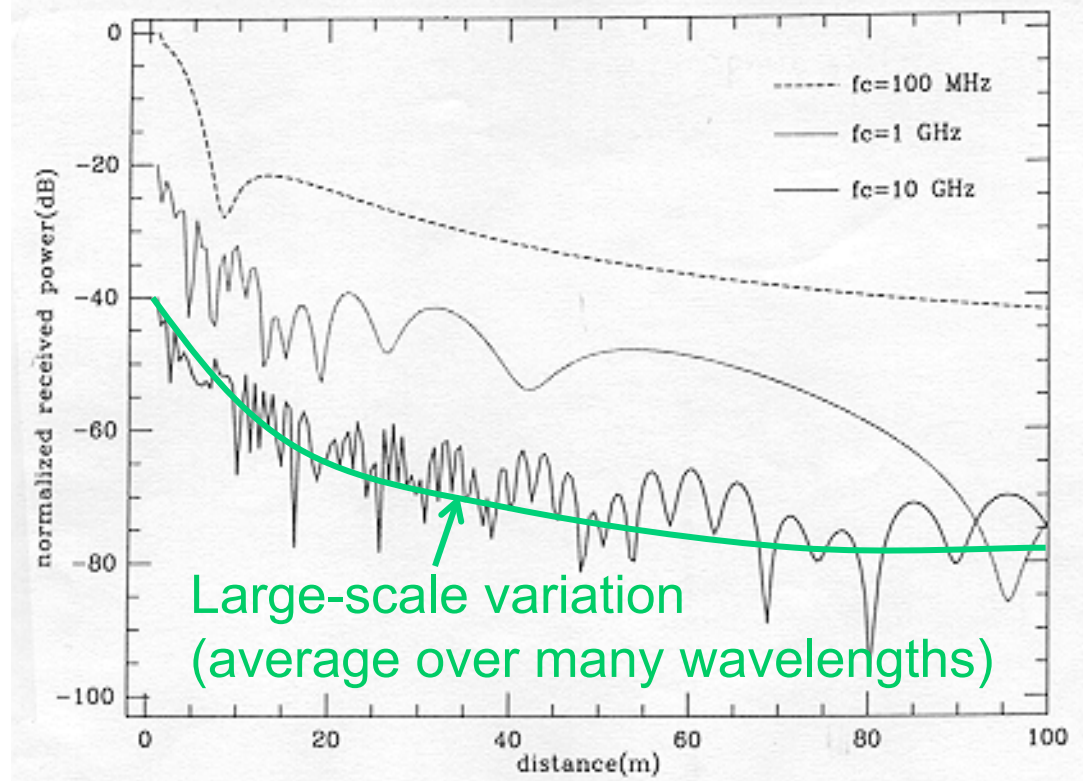
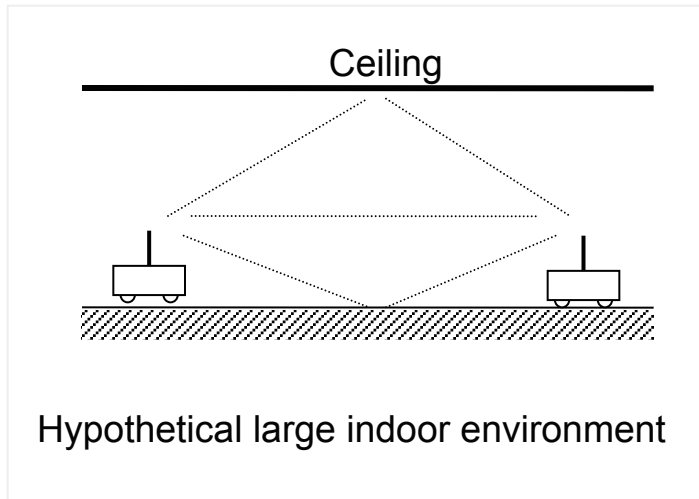

Normalized received power vs. distance

# Indoor Propagation Measurements

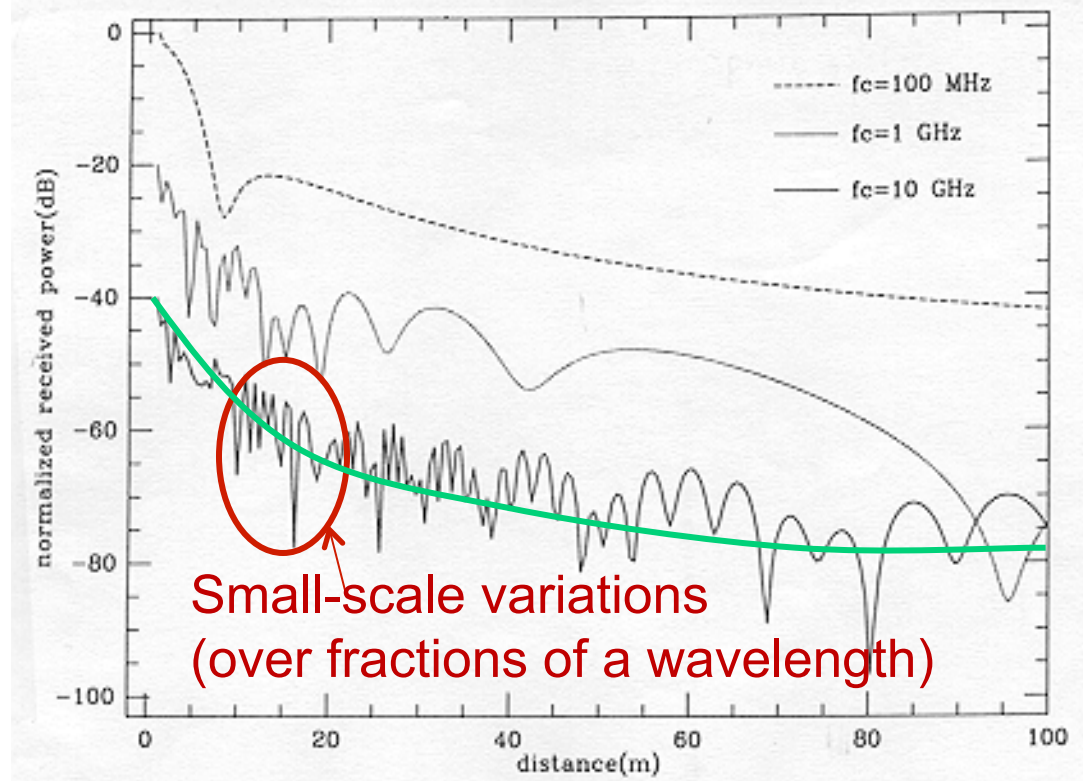
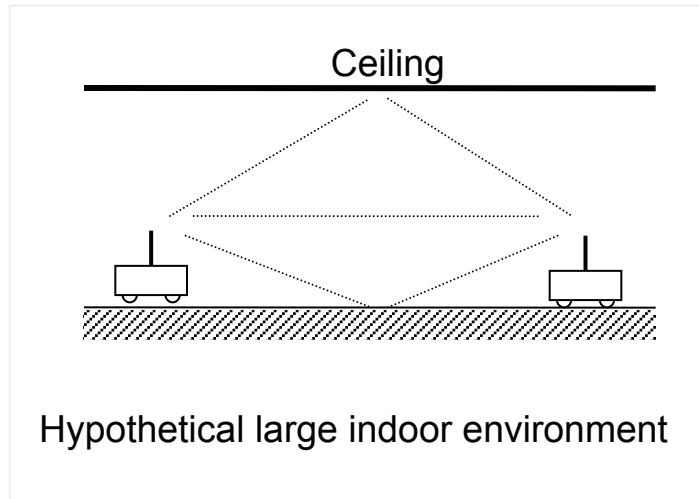

Normalized received power vs. distance



# Power Attenuation

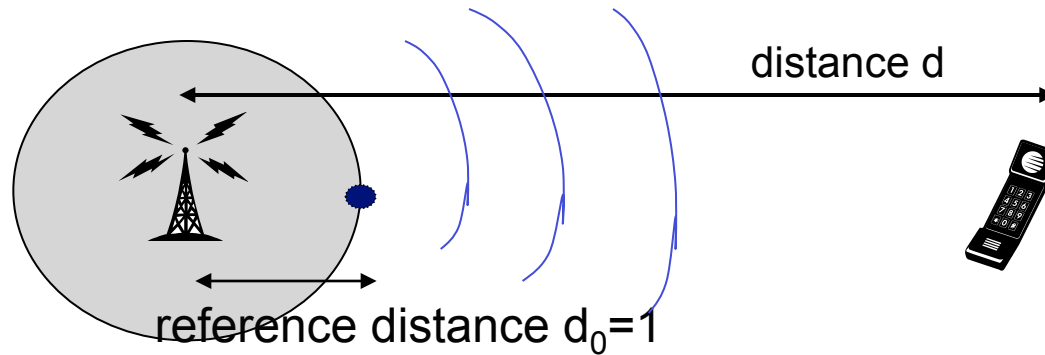

$$\text{Received power } P_r \approx P_0 \left( \frac{d}{d_0} \right)^{-n}$$

Reference power at reference distance  $d_0$

Path loss exponent

In dB:  $P_r = P_0 \text{ (dB)} - 10 n \log (d)$

$P_r \text{ (dB)}$

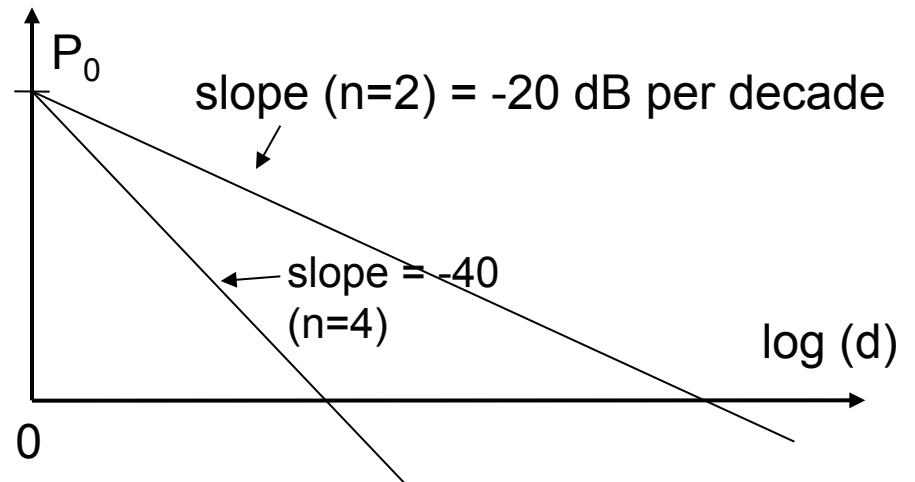



# Path Loss Exponents

ENVIRONMENT	PATH LOSS EXPONENT, $n$
Free space	2
Urban cellular radio	2.7 to 3.5
Shadowed urban cellular radio	3 to 5
In building line-of-site	1.6 to 1.8
Obstructed in building	4 to 6
Obstructed in factories	2 to 3



# Large-Scale Path Loss (Scatter Plot)

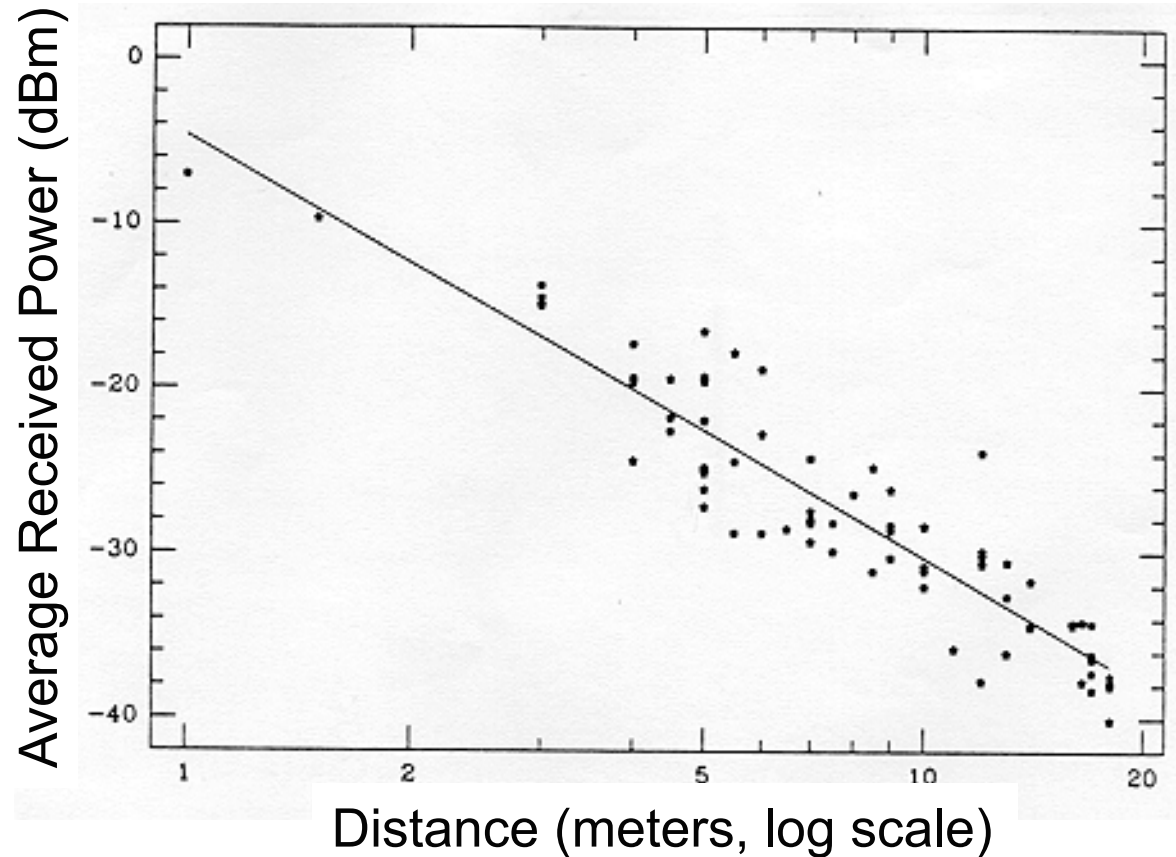

# Shadow Fading

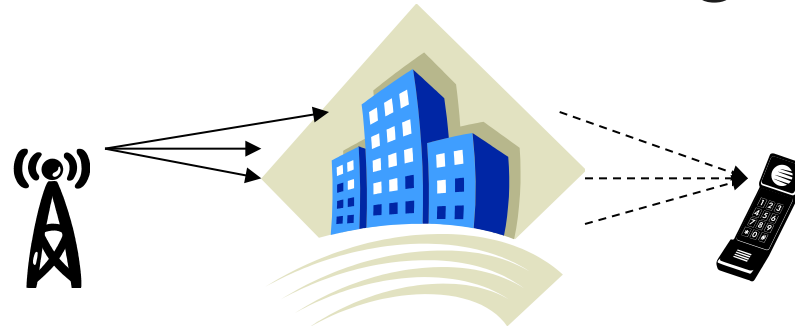

- Random variations in **path loss** as mobile moves around buildings, trees, etc.
- Modeled as an additional random variable:

“normal” (Gaussian)  
probability distribution

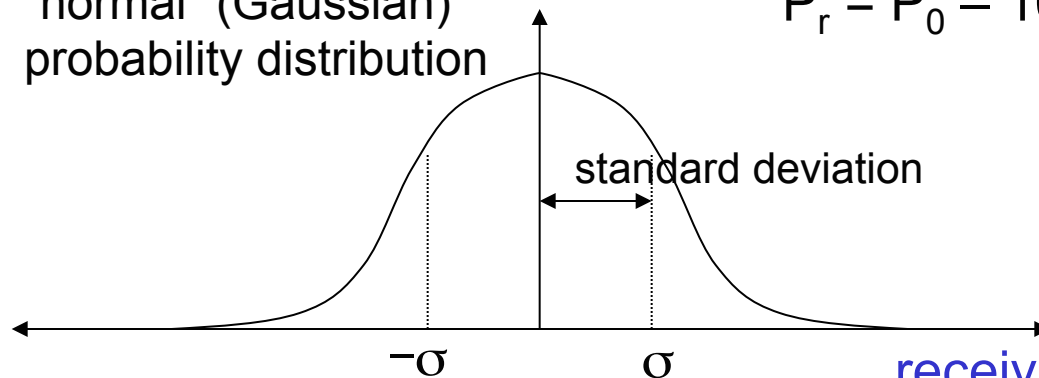

$$P_r = P_0 - 10 n \log d + X$$

“log-normal” random variable

For cellular:  $\sigma$  is about 8 dB



# Large-Scale Path Loss (Scatter Plot)

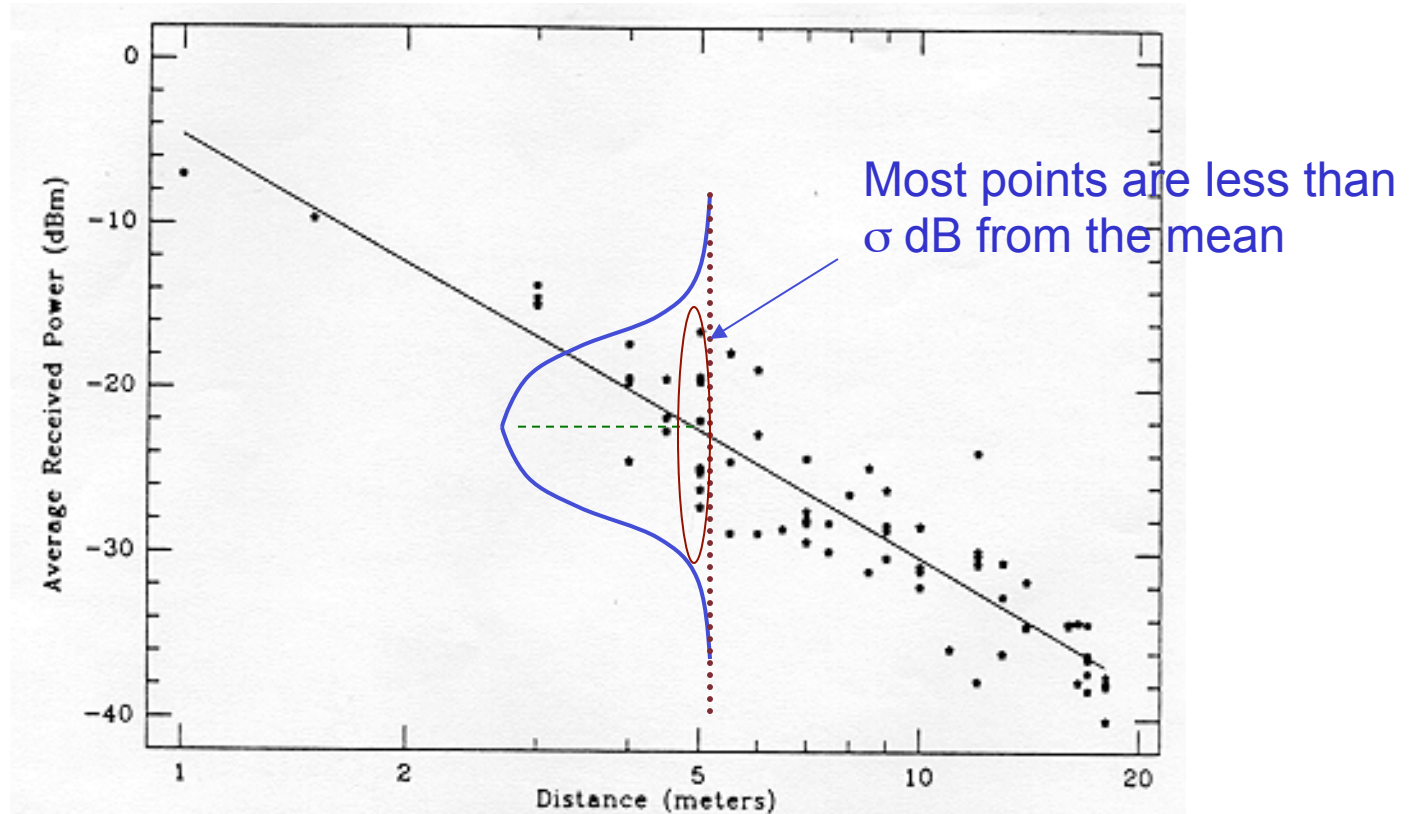



# Empirical Path Loss Models

- Propagation studies must take into account:
  - Environment (rural, suburban, urban)
  - Building characteristics (high-rise, houses, shopping malls)
  - Vegetation density
  - Terrain (mountainous, hilly, flat)
- Okumura's model  
(based on measurements in and around Tokyo)
  - Median path loss =  
free-space loss + urban loss + antenna gains + corrections
  - Obtained from graphs
  - Additional corrections for street orientation, irregular terrain
- Numerous indoor propagation studies for 802.11



# SINR Measurements: 1xEV-DO

drive test plots



## dB and dBm

- **dB** is a ratio of two powers:

We say that power  $P_1$  is  $x$  dB stronger than power  $P_2$  if  $x = 10 \log (P_1/P_2)$ , where log is base 10.

– Example:  $P_1$  is 3 dB more than  $P_2$  if  $P_1/P_2 \approx 2$ .

- **dBm** is power relative to a milliwatt (1 mW = 0.001 W):

$P$  in dBm =  $10 \log (P/0.001)$

– Example: 1 mW =  $10 \log 1 = 0$  dBm



# Link Budget

How much transmit power is required to achieve a target received power?

- dBs add:

Target received power (dBm)

+ path loss (dB)

+ other losses (components) (dB)

- antenna gains (dB)

---

Total power needed at transmitter (dBm)



## Example

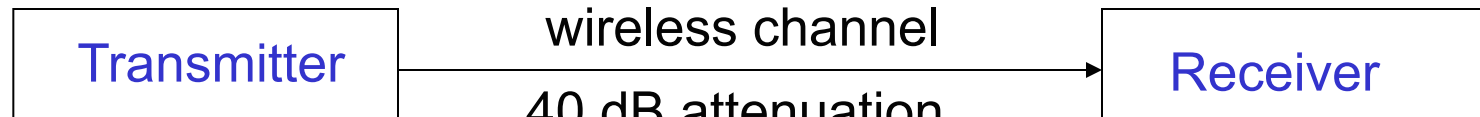

What is the required  
Transmit power?

Received power  
must be  $> -30$  dBm

- Recall that dBm measures the signal power relative to 1 mW (milliwatt) = 0.001 Watt. To convert from S Watts to dBm, use  $S \text{ (dBm)} = 10 \log (S / 0.001)$
- Transmitted power (dBm) =  $-30 + 40 = 10$  dBm = 10 mW
- What if the received signal-to-noise ratio must be 5 dB, and the noise power is -45 dBm?



# Urban Multipath

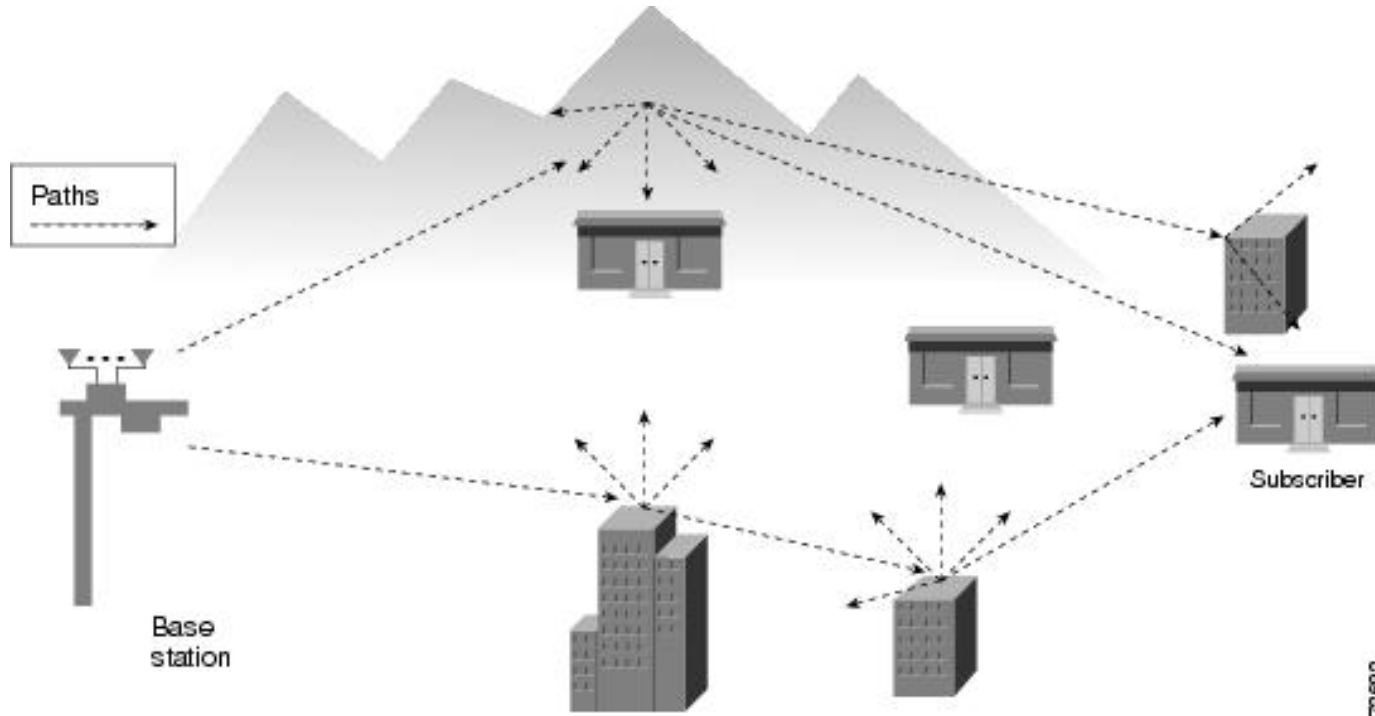

78692

- No direct Line of Sight between mobile and base
- Radio wave scatters off of buildings, cars, etc.
- Severe multipath



## Narrowband vs. Wideband

- **Narrowband** means that the bandwidth of the transmitted signal is small (e.g.,  $< 100$  kHz for cellular). It therefore looks “almost” like a sinusoid.
  - Multipath changes the amplitude and phase.
- **Wideband** means that the transmitted signal has a large bandwidth (e.g.,  $> 1$  MHz for cellular).
  - Multipath causes “self-interference”.



# Narrowband Fading

$$\text{Received signal } r(t) = h_1 s(t - \tau_1) + h_2 s(t - \tau_2) + h_3 s(t - \tau_3) + \dots$$

attenuation  
for path 1 (random)

delay for path 1 (random)

If the transmitted signal is sinusoidal (narrowband),  $s(t) = \sin 2\pi f t$ , then the received signal is also sinusoidal, but with a different (random) amplitude and (random) phase:

$$r(t) = A \sin (2\pi f t + \theta)$$

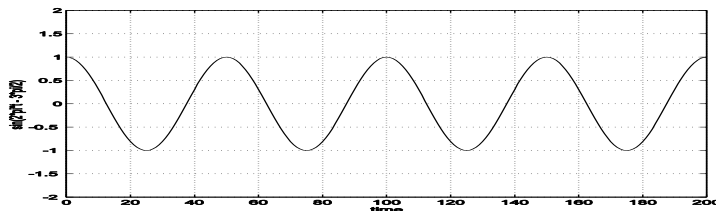

Transmitted  $s(t)$

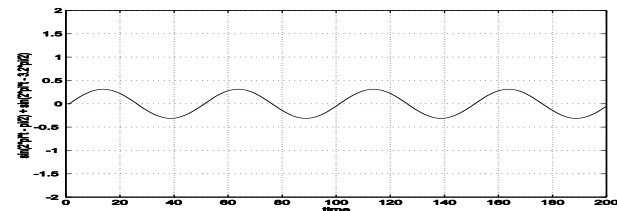

Received  $r(t)$

$A, \theta$  depend on environment, location of transmitter/receiver



# Rayleigh Fading

Can show:

A has a “Rayleigh” distribution

$\theta$  has a “uniform” distribution

(all phase shifts are equally likely)

Probability ( $A < a$ ) =  $1 - e^{-a^2/P_0}$

where  $P_0$  is the reference power (averaged over different locations)

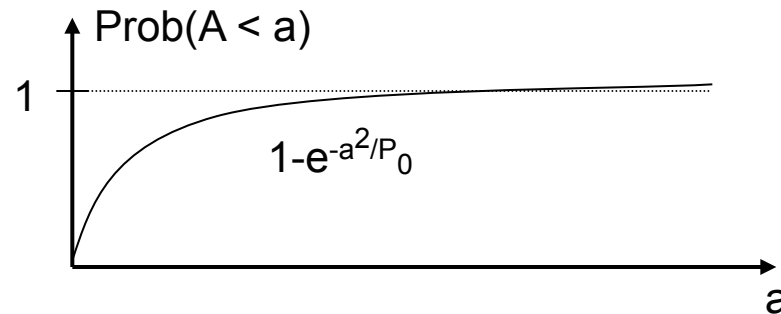

Ex:  $P_0 = 1, a=1$ :  $\text{Pr}(A < 1) = 1 - e^{-1} = 0.63$  (probability that signal is faded)

$P_0 = 1, a=0.1$ :  $\text{Pr}(A < 0.1) = 1 - e^{-1/100} \approx 0.01$

(prob that signal is severely faded)



# Small-Scale (Rayleigh) Fading

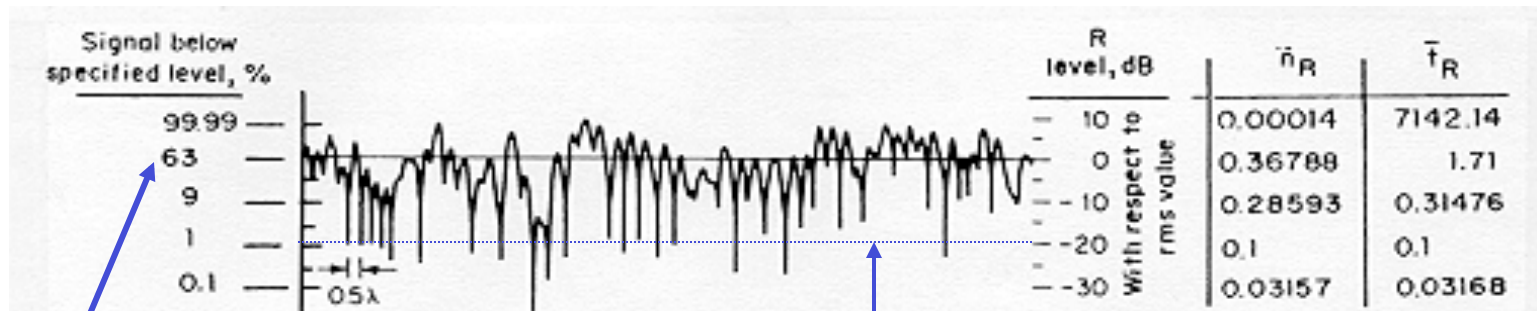

The signal strength falls below the average 63% of the time.

$a = 0.1$

(from Fig. 1.10)

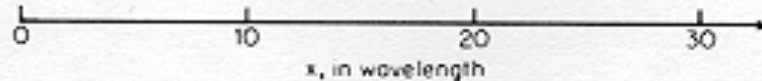
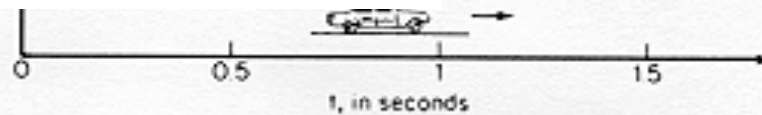

$$p(R) = Re^{-R^2} \quad \text{cumulative probability distribution}$$

$$\bar{n}(R) = \frac{\beta V}{\sqrt{2\pi}} \times n_R \quad \text{level crossing rate}$$

$$\bar{t}(R) = \frac{\sqrt{2\pi}}{\beta V} \times \bar{t}_R \quad \text{average duration of fades}$$



# Small-Scale (Rayleigh) Fading

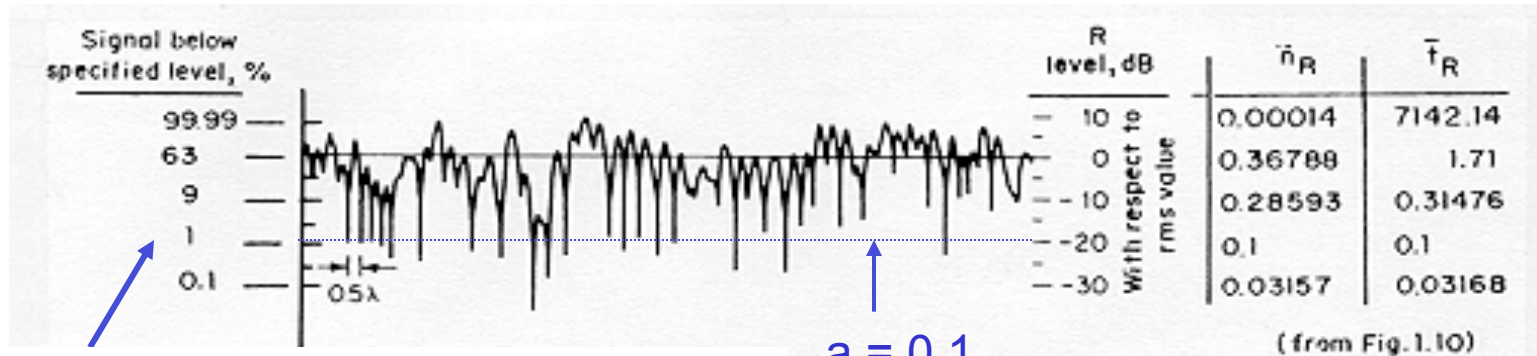

The signal power falls > 10 dB below the average 1% of the time.

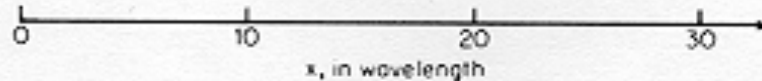
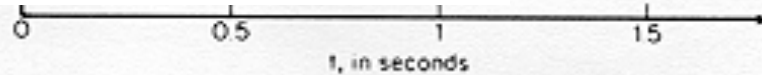

$$p(R) = Re^{-R^2} \quad \text{cumulative probability distribution}$$

$$\bar{n}(R) = \frac{\beta V}{\sqrt{2\pi}} \times n_R \quad \text{level crossing rate}$$

$$\bar{t}(R) = \frac{\sqrt{2\pi}}{\beta V} \times \bar{t}_R \quad \text{average duration of fades}$$



# Small-Scale Fading

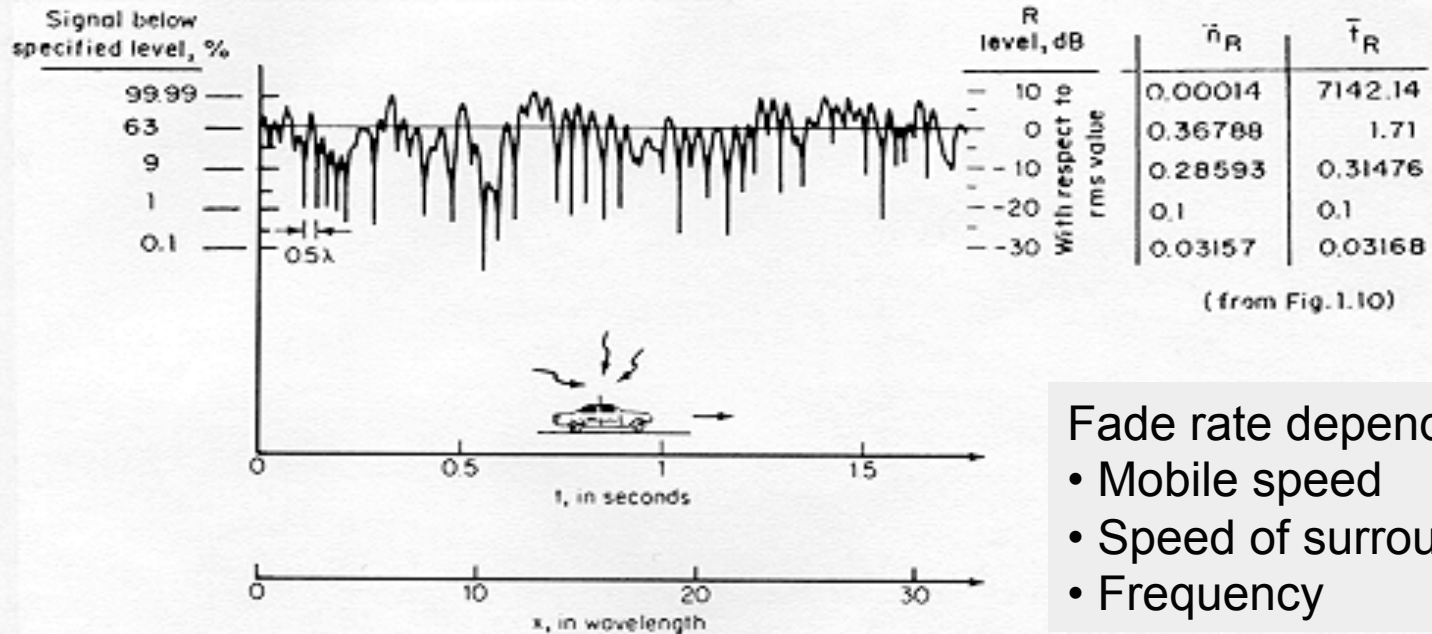

- Fade rate depends on
- Mobile speed
  - Speed of surrounding objects
  - Frequency

$$p(R) = Re^{-R^2} \quad \text{cumulative probability distribution}$$

$$\bar{n}(R) = \frac{\beta V}{\sqrt{2\pi}} \times n_R \quad \text{level crossing rate}$$

$$\bar{t}(R) = \frac{\sqrt{2\pi}}{\beta V} \times \bar{t}_R \quad \text{average duration of fades}$$



# Short- vs. Long-Term Fading

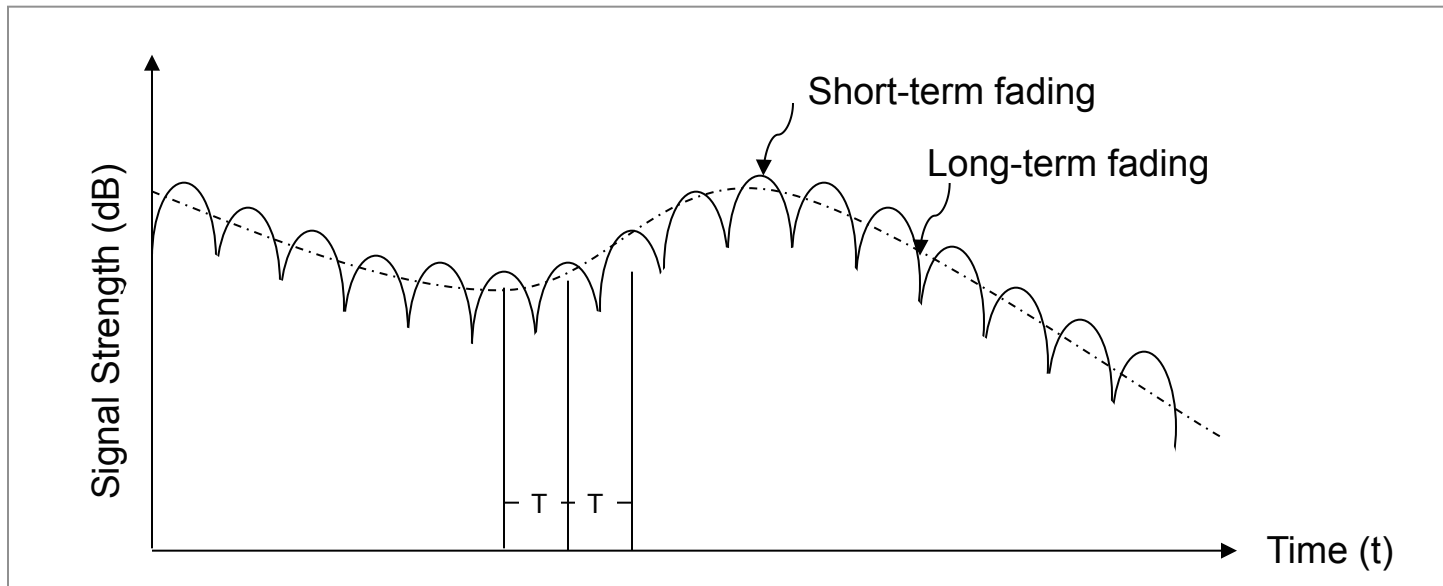

## Long-term (large-scale) fading:

- Distance attenuation
- Shadowing (blocked Line of Sight (LOS))
- Variations of signal strength over distances on the order of many wavelengths



# Combined Fading and Attenuation

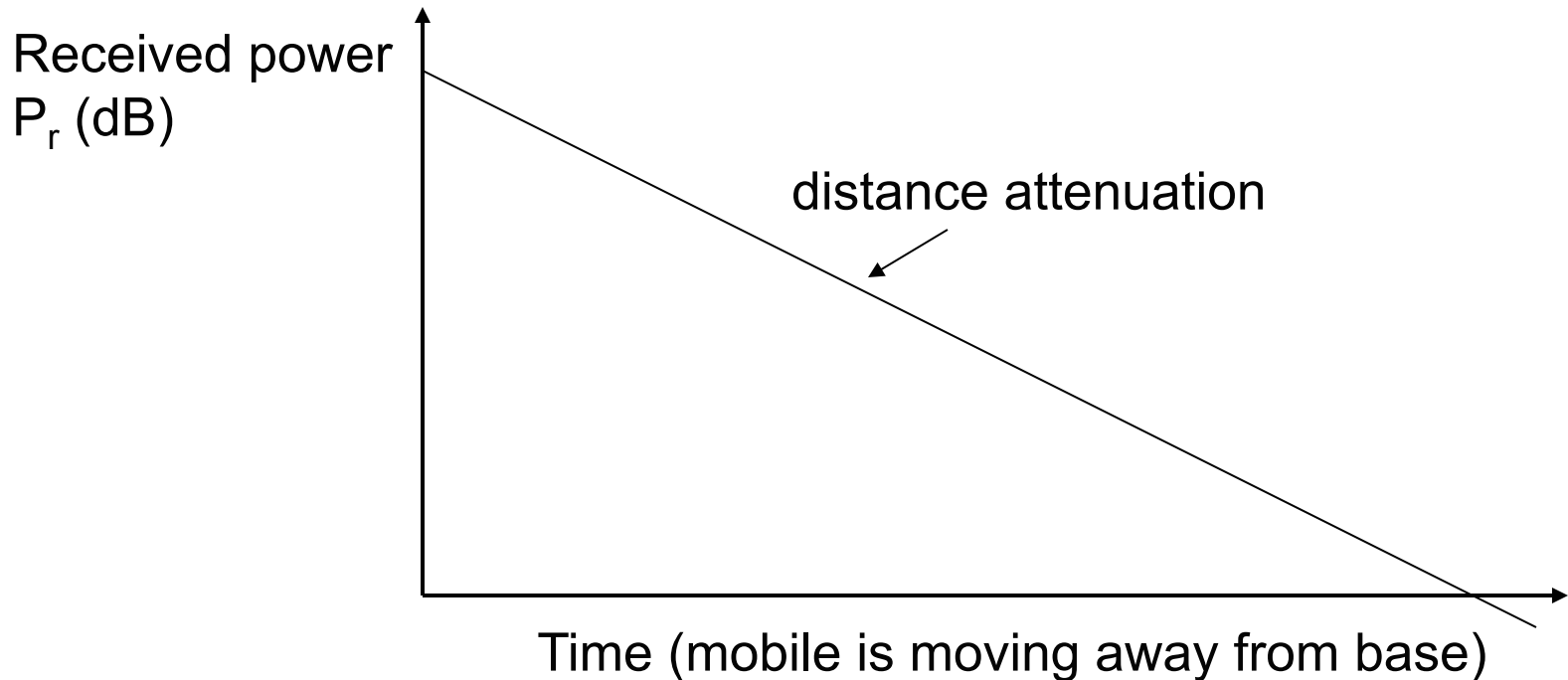



# Combined Fading and Attenuation

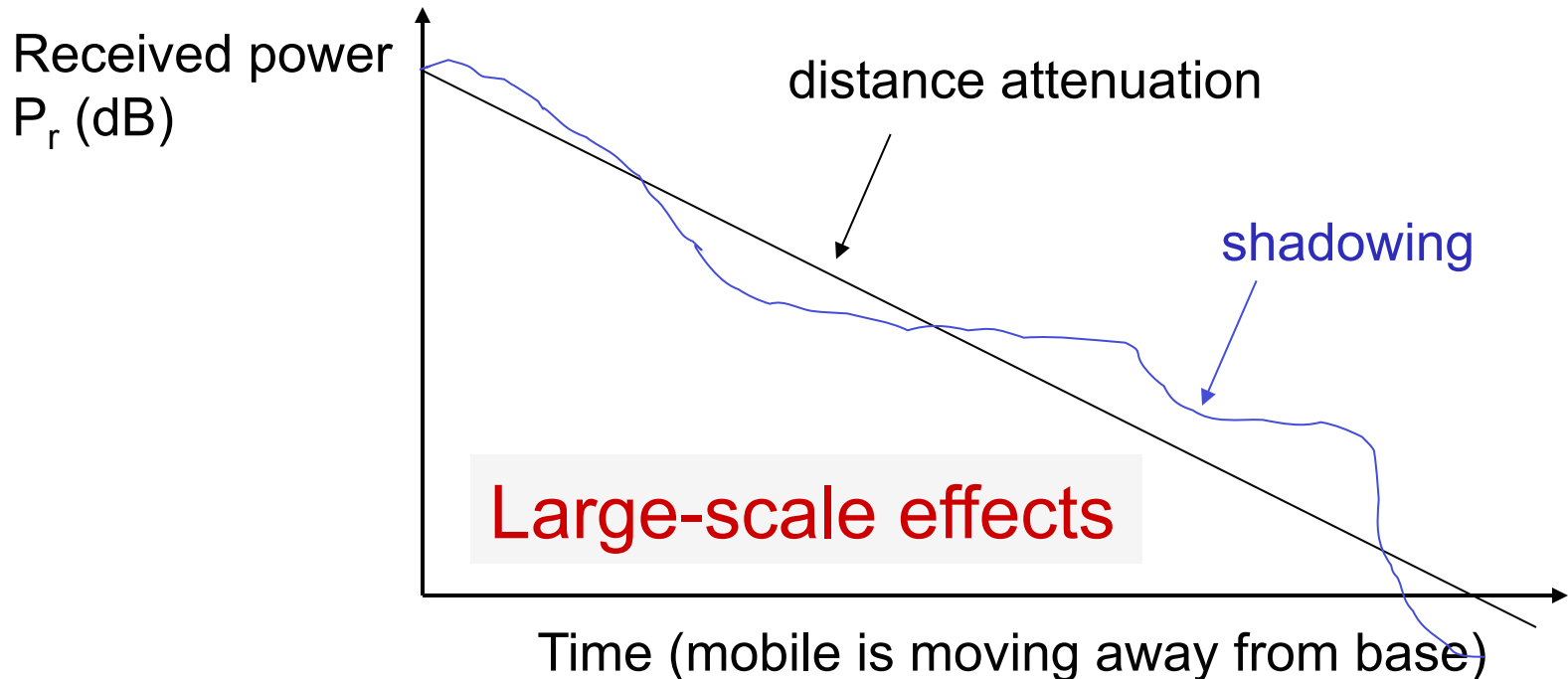



# Combined Fading and Attenuation

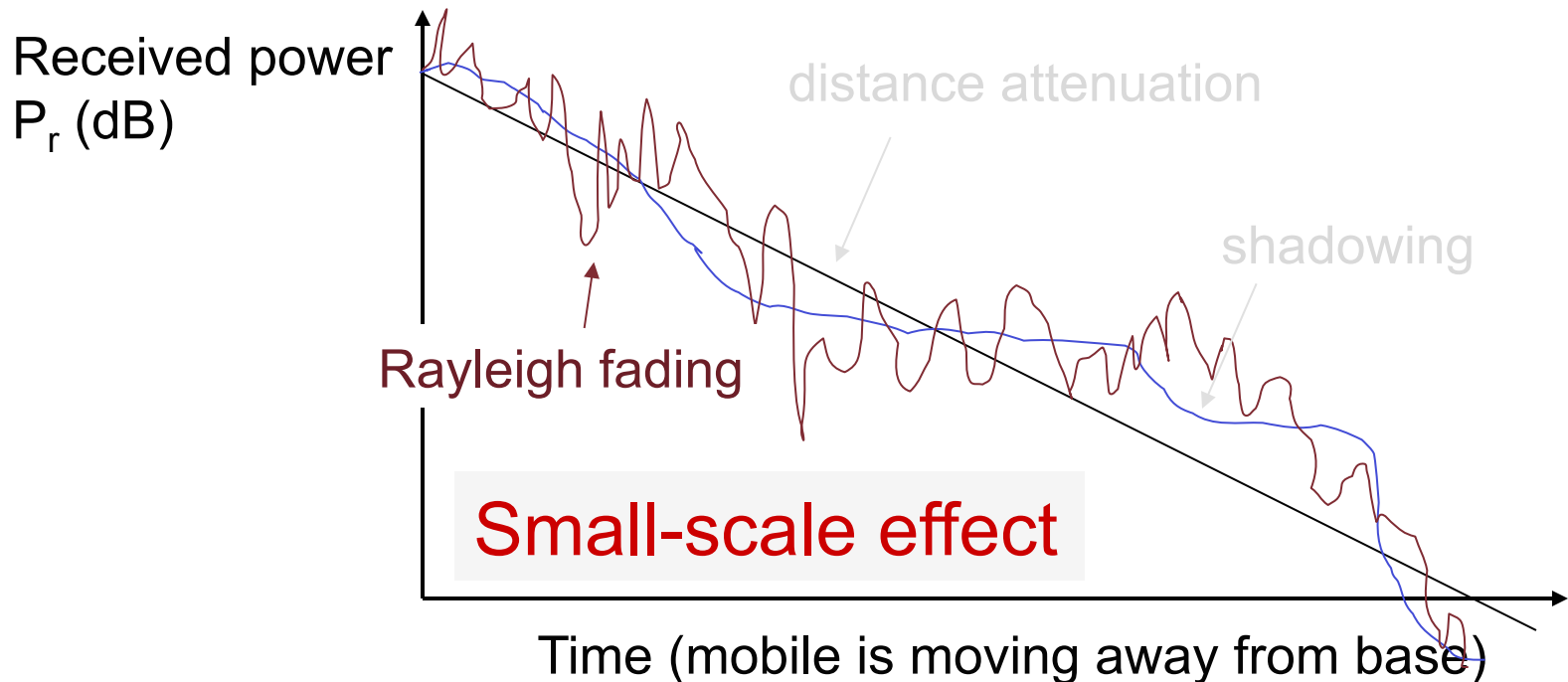



---

# Example Diagnostic Measurements: 1XEV-DO

drive test measurements

drive path



# Time Variations: Doppler Shift

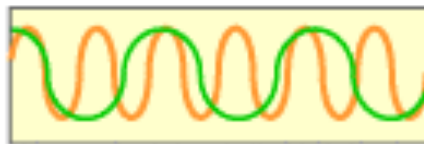
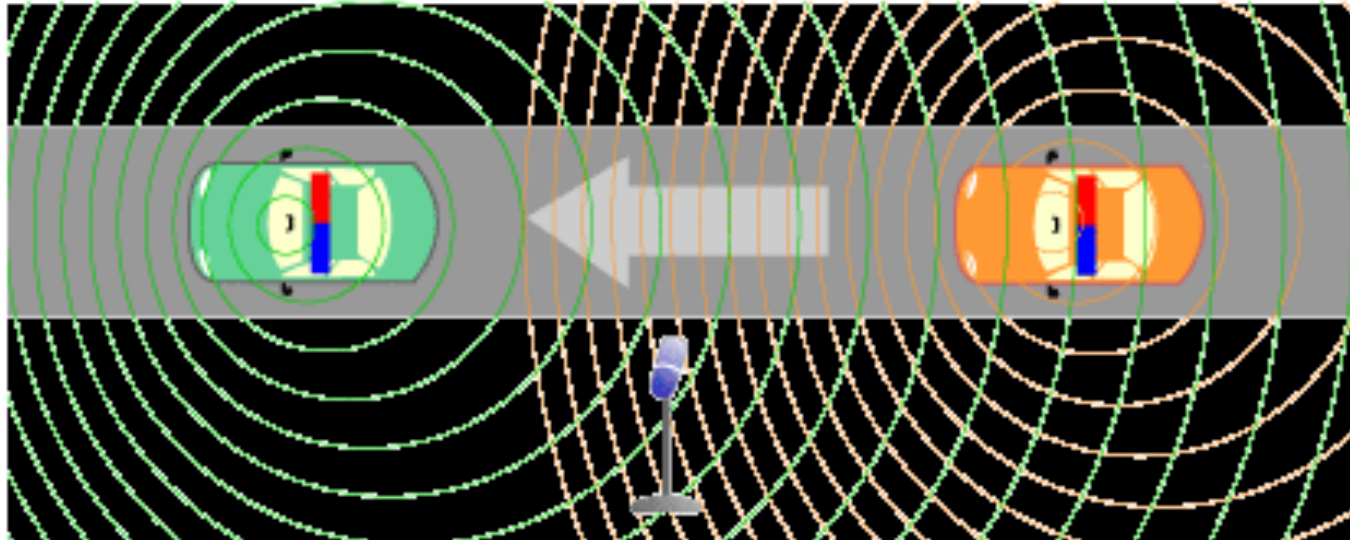

[Audio clip \(train station\)](#)

[Audio clip \(siren\)](#)



# Time Variations: Doppler Shift

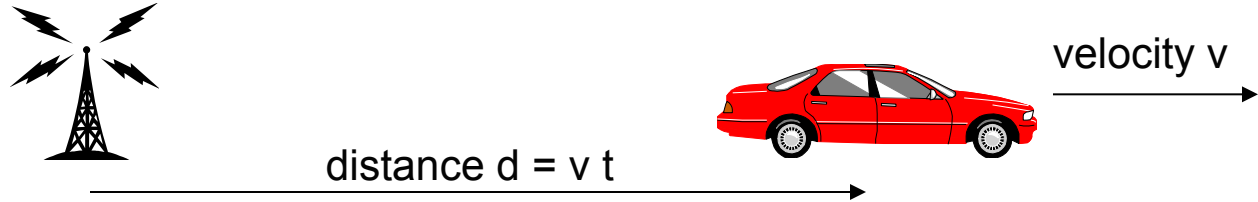

Propagation delay = distance  $d$  / speed of light  $c = vt/c$

transmitted  
signal  $s(t)$

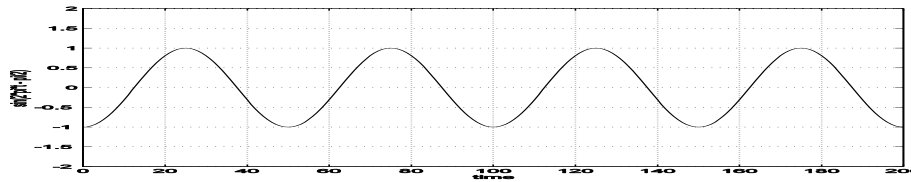

delay increases

received  
signal  $r(t)$

propagation  
delay

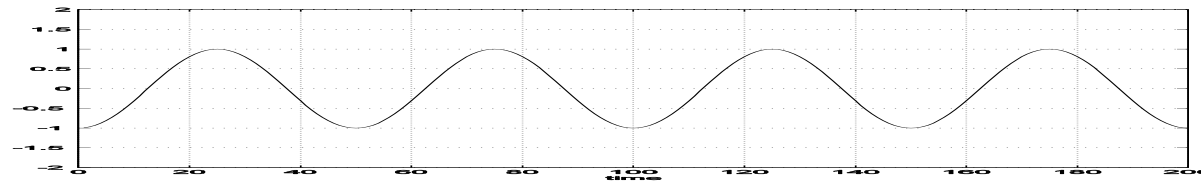

$$\text{Received signal } r(t) = \sin 2\pi f (t - vt/c) = \sin 2\pi (f - fv/c) t$$

received frequency

Doppler shift  $f_d = -fv/c$



## Doppler Shift (Ex)

Mobile moving away from base →  $v > 0$ , Doppler shift  $< 0$

Mobile moving towards base →  $v < 0$ , Doppler shift  $> 0$

Carrier frequency  $f = 900$  MHz,  $v = 60$  miles/hour = 26.82 meters/sec

Mobile → Base:  $f_d = fv/c = (900 \times 10^6) \times 26.82 / (3 \times 10^8) \approx 80$  Hz  
meters/sec



# Doppler (Frequency) Shift

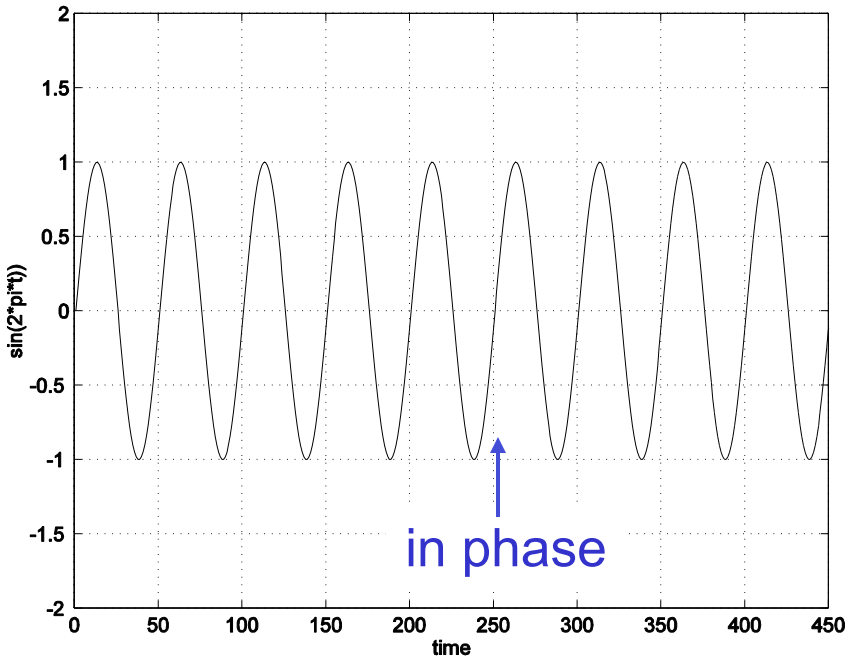

Frequency=  $1/50$

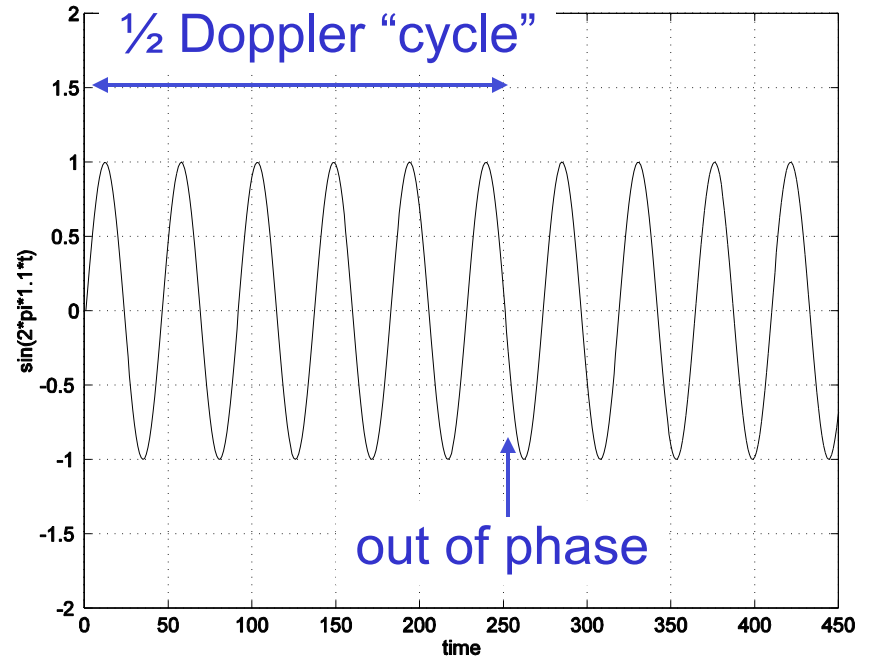

Frequency=  $1/45$



# Application of Doppler Shift: Astronomy

Doppler shift determines relative velocity of distant objects (e.g., stars, galaxies...)

“red shift”: object is moving away

“blue shift” object is moving closer

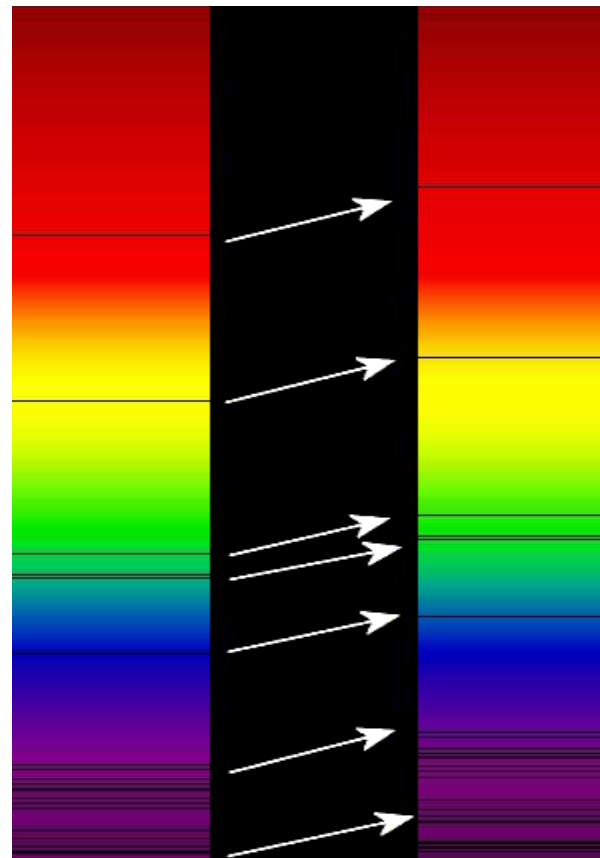

Observed “spectral lines” (radiation is emitted at discrete frequencies)

sun light spectrum

spectrum of galaxy supercluster

## Application of Doppler Shift: Police Radar

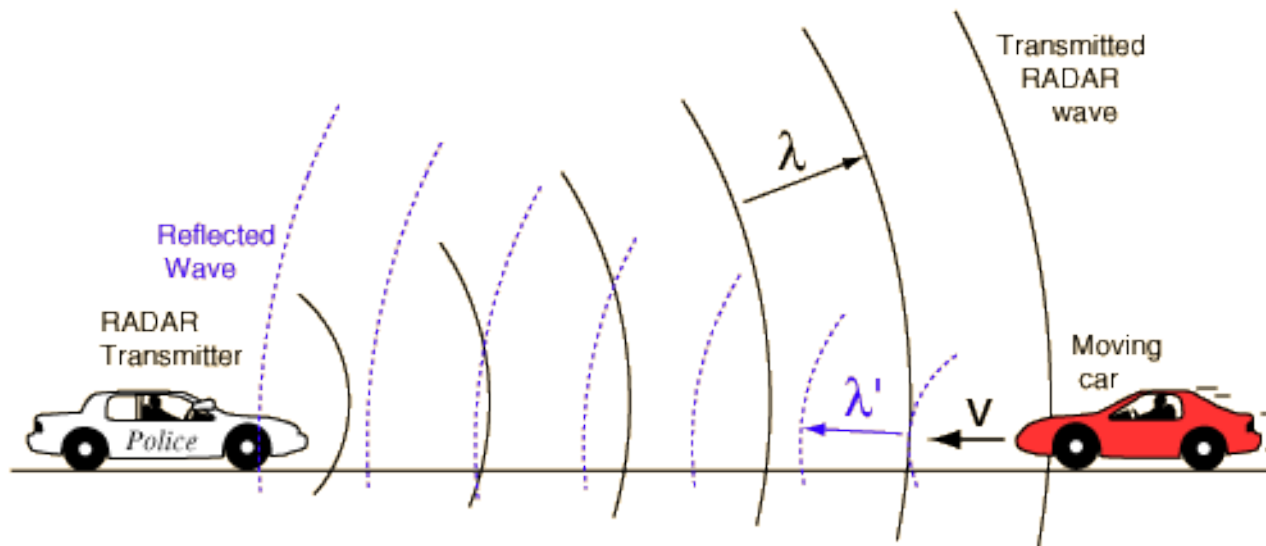

Doppler shift can be used to compute relative speed.



# Scattering: Doppler Spectrum

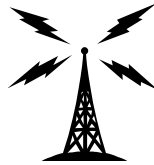

distance  $d = v t$

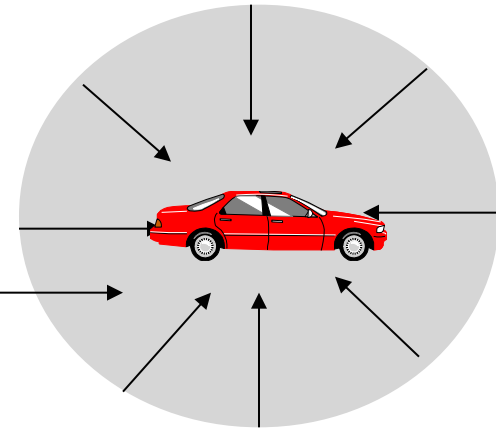

received signal ??

transmitted signal  $s(t)$

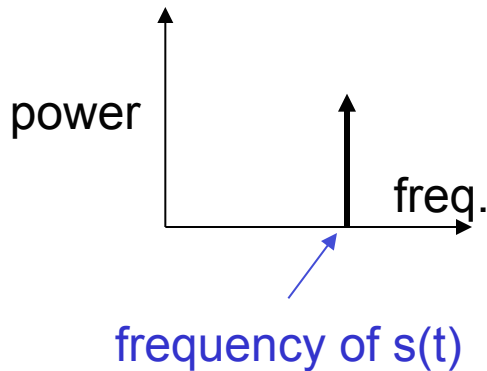
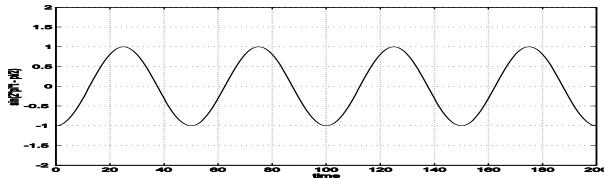

- Received signal is the sum of all scattered waves
- Doppler shift for each path depends on angle ( $v f \cos \theta / c$ )
- Typically assume that the received energy is the same from all directions (uniform scattering)



# Scattering: Doppler Spectrum

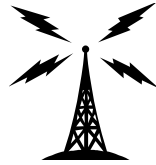

distance  $d = v t$

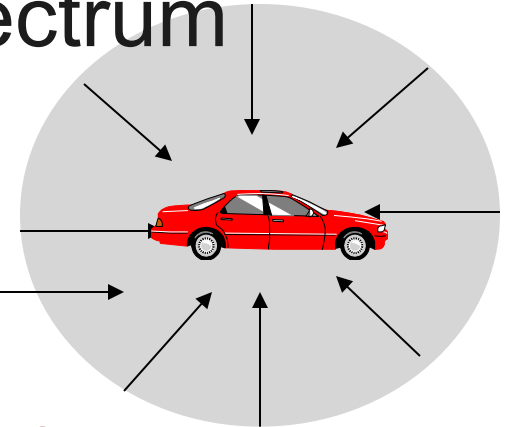

transmitted  
signal  $s(t)$

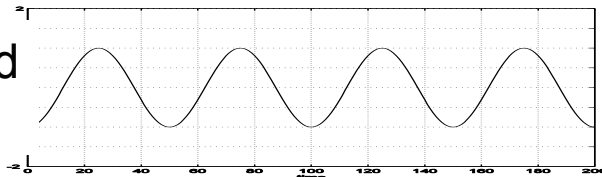

## Doppler Spectrum

(shows relative strengths of Doppler shifts)

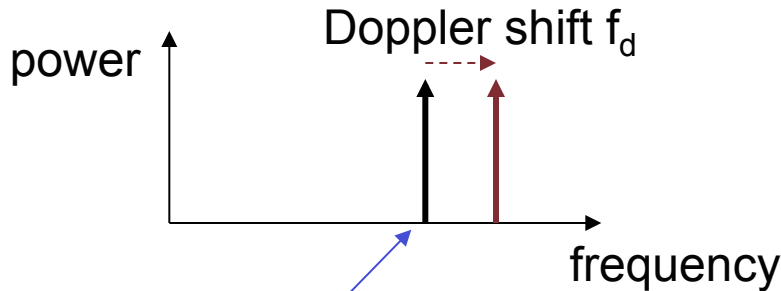

frequency of  $s(t)$

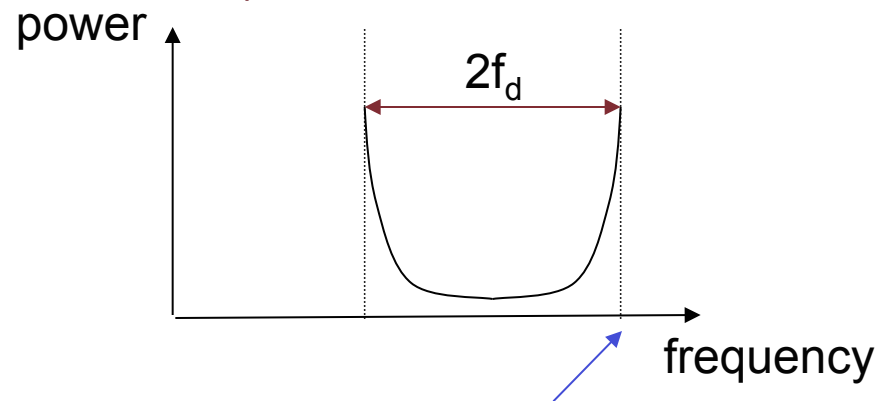

frequency of  $s(t) + \text{Doppler shift } f_d$



# Scattering: Doppler Spectrum

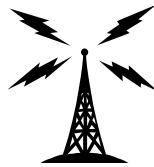

distance  $d = v t$

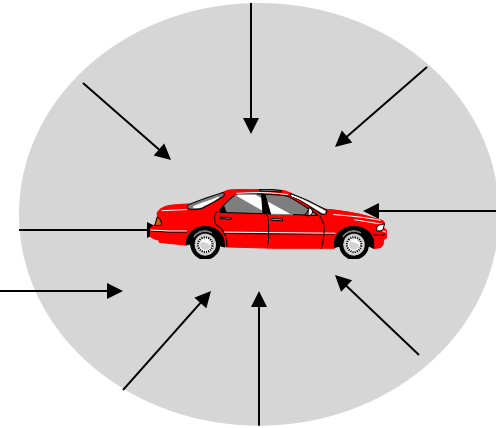

transmitted  
signal  $s(t)$

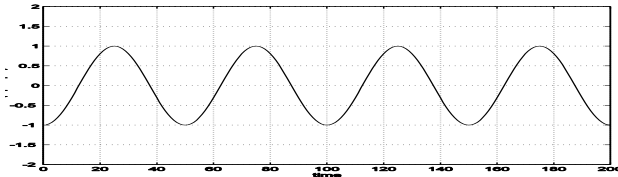

power

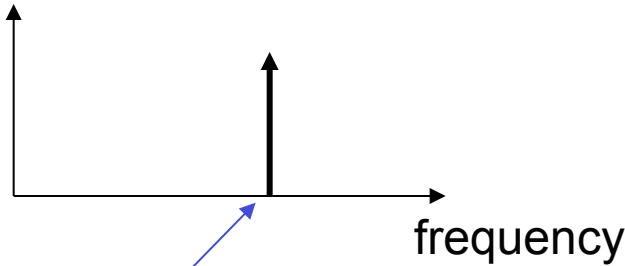

frequency of  $s(t)$

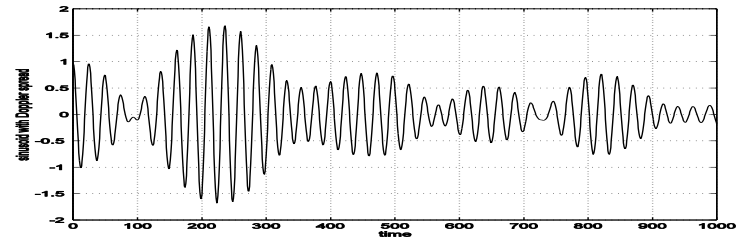

Doppler spectrum

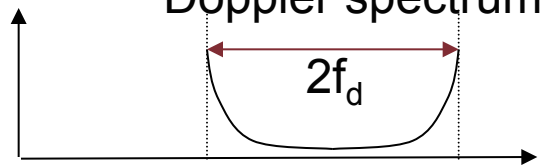

frequency of  $s(t) + \text{Doppler shift } f_d$



# Rayleigh Fading

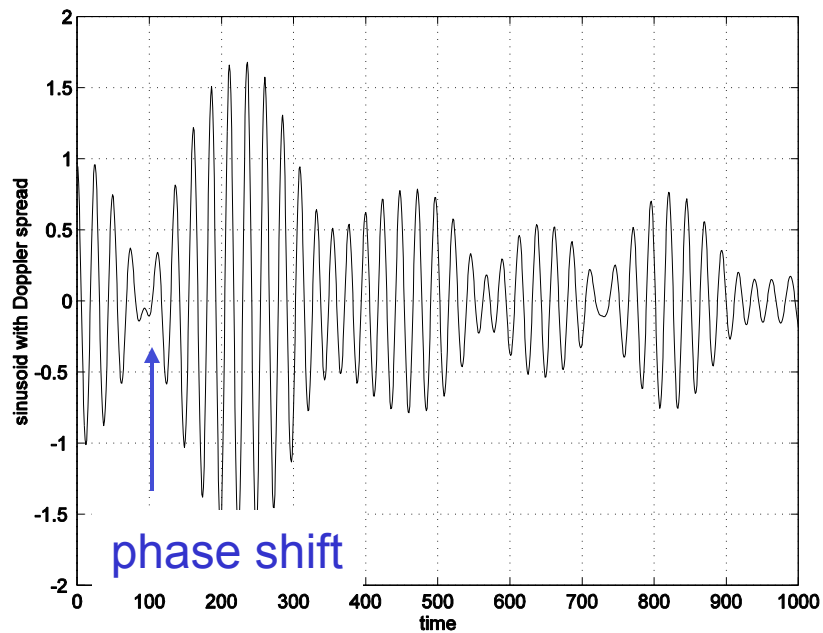

Received waveform

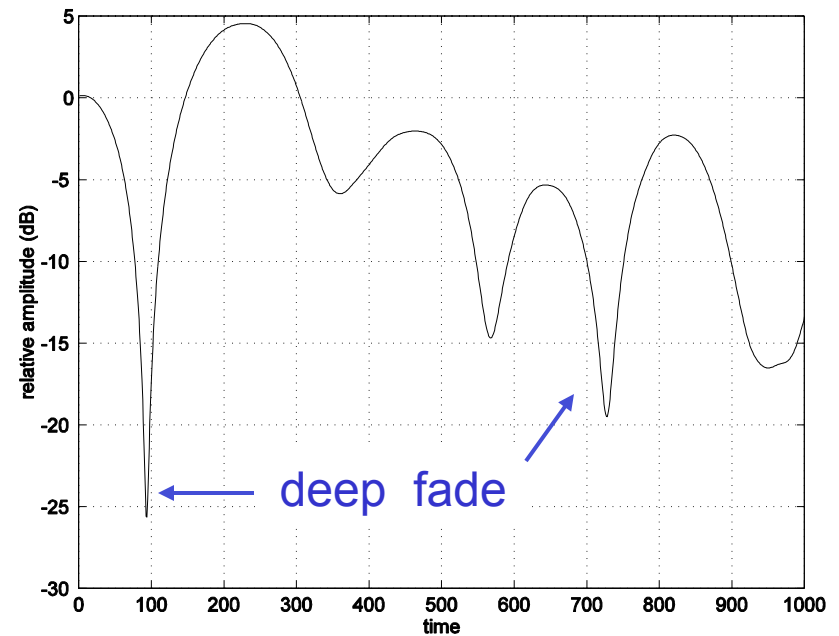

Amplitude (dB)



# Channel Coherence Time

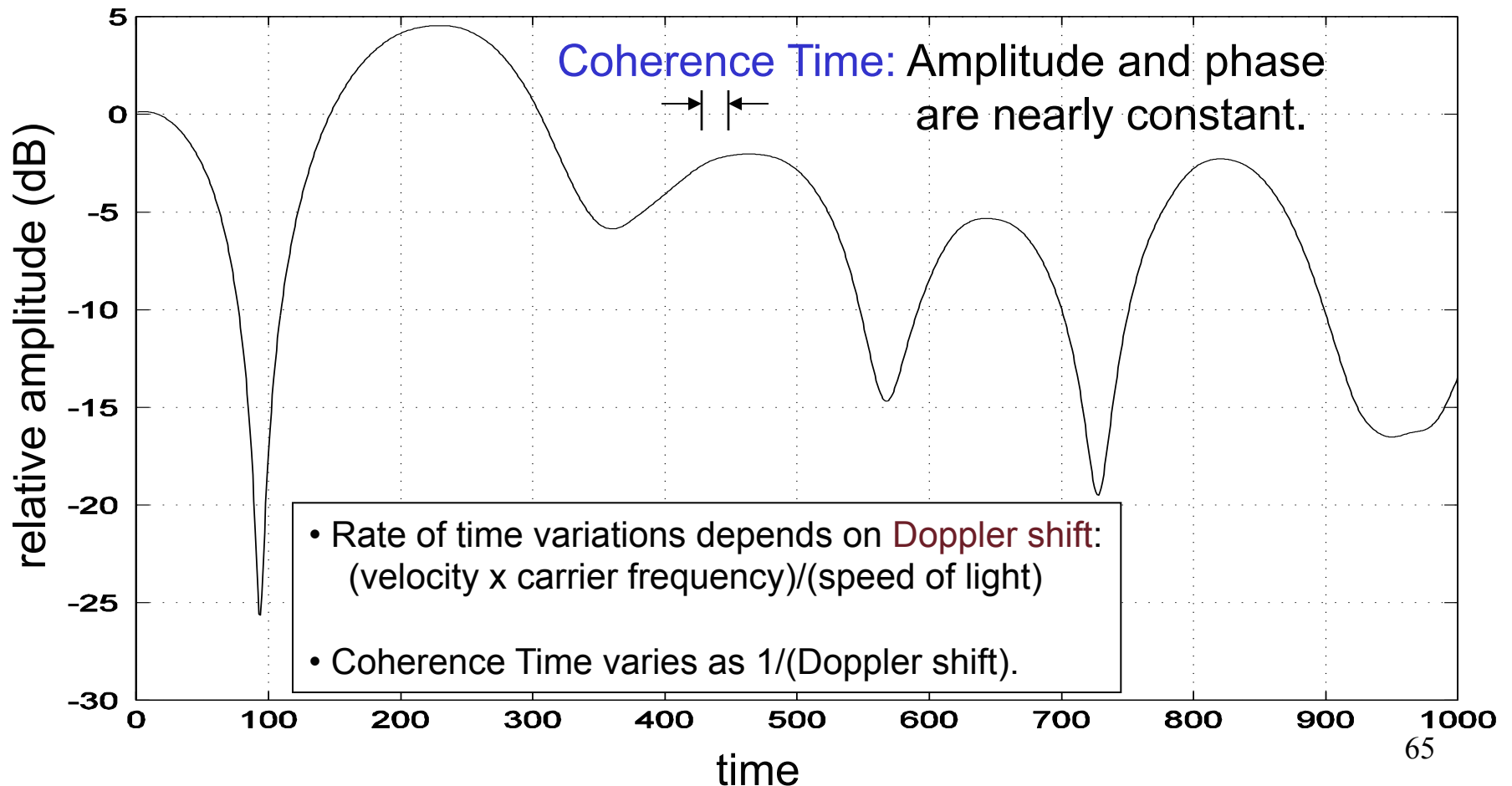



## Fast vs. Slow Fading

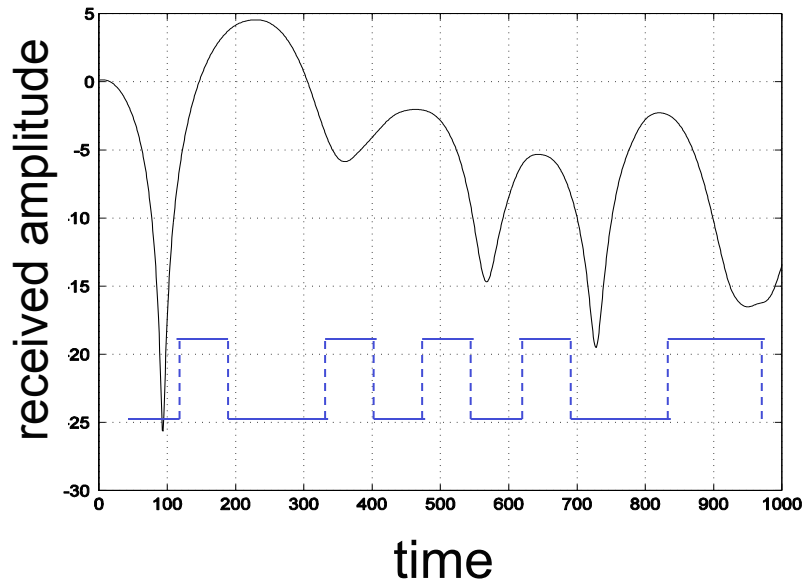

**Fast fading:** channel changes every few symbols. Coherence time is less than roughly 100 symbols.

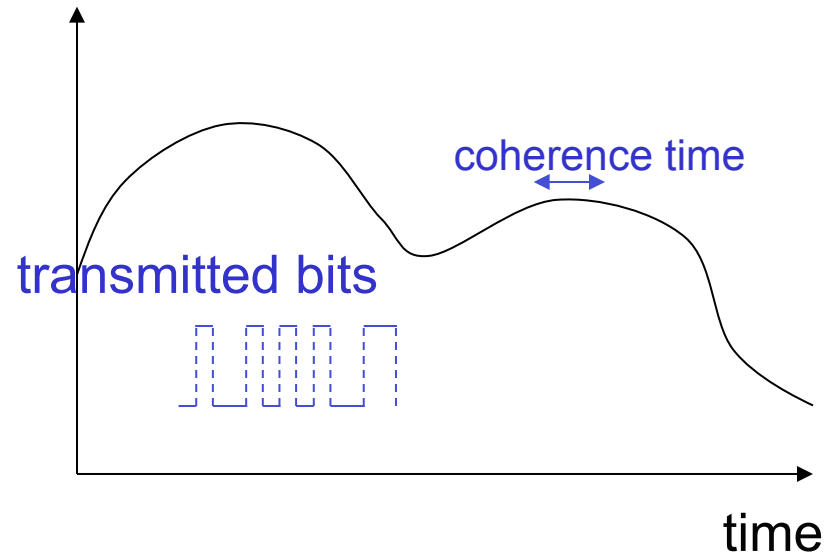

**Slow fading:** Coherence time lasts more than a few 100 symbols.



# Fast vs. Slow Fading

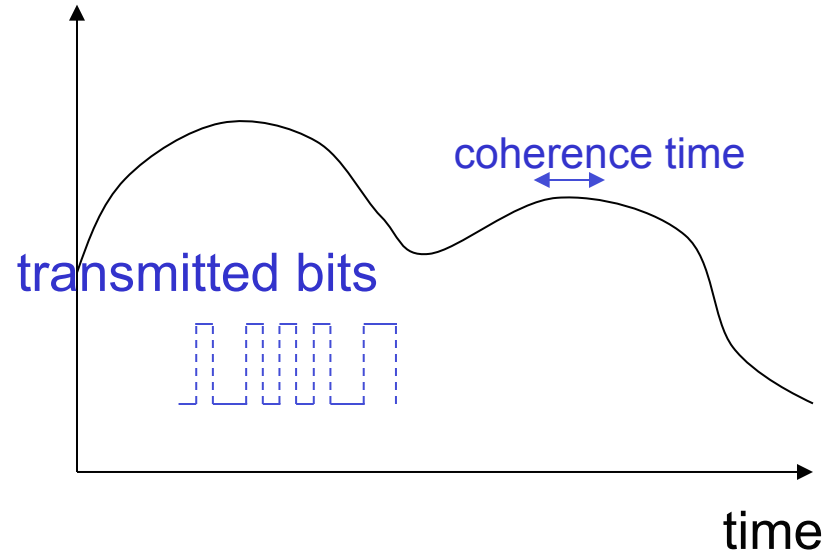
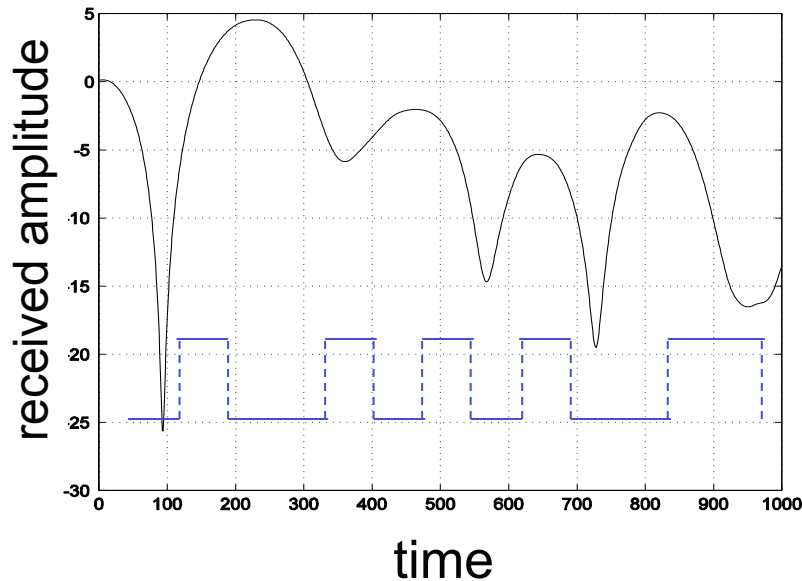

What is important is the coherence time ( $1/\text{Doppler}$ )  
relative to the Data rate.



## Fade Rate (Ex)

- $f_c = 900$  MHz,  $v = 60$  miles/hour  
→ Doppler shift  $\approx 80$  Hz.  
Coherence time is roughly  $1/80$ , or 10 msec
- Data rate (voice): 10 kbps or 0.1 msec/bit  
→ 100 bits within a coherence time (fast fading)
- GSM data rate: 270 kbps → about 3000 bits within a coherence time (slow fading)



# Channel Characterizations: Narrowband vs. Wideband

## Narrowband signal (sinusoid)

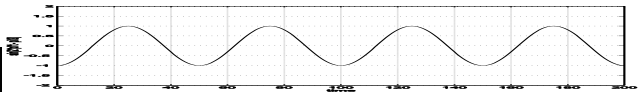
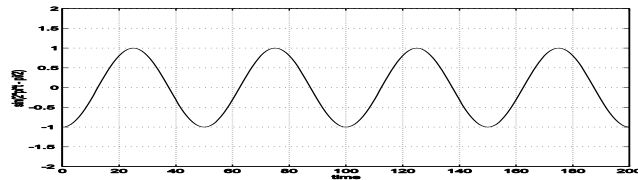

Amplitude attenuation,  
Delay (phase shift)

infinite duration, zero bandwidth

## Wideband signal (impulse)

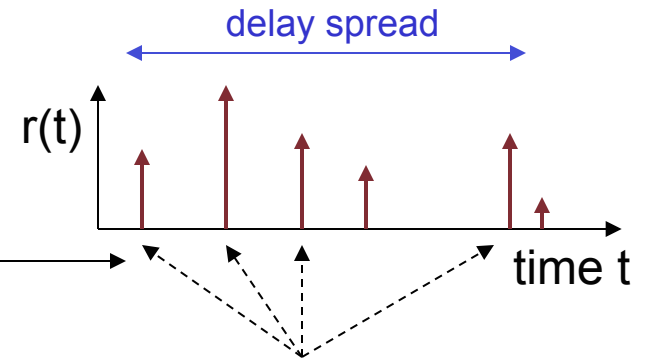
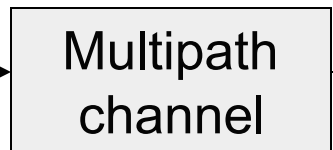
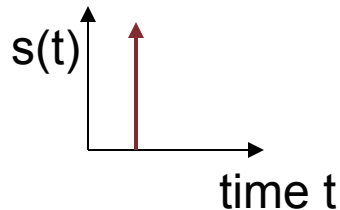

zero duration, infinite bandwidth



# Pulse Width vs. Bandwidth

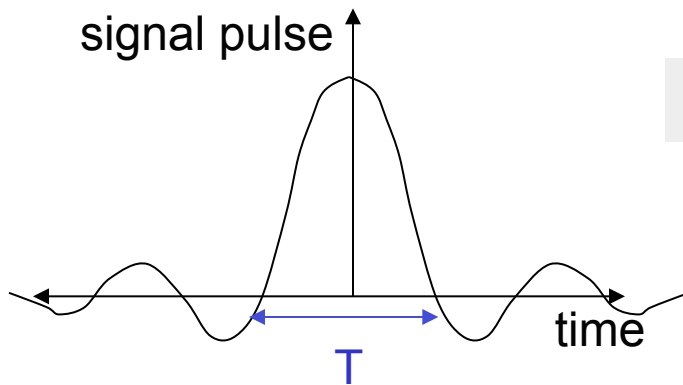

Narrowband

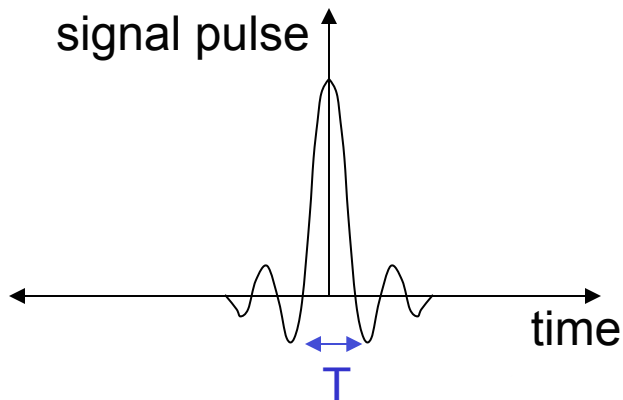
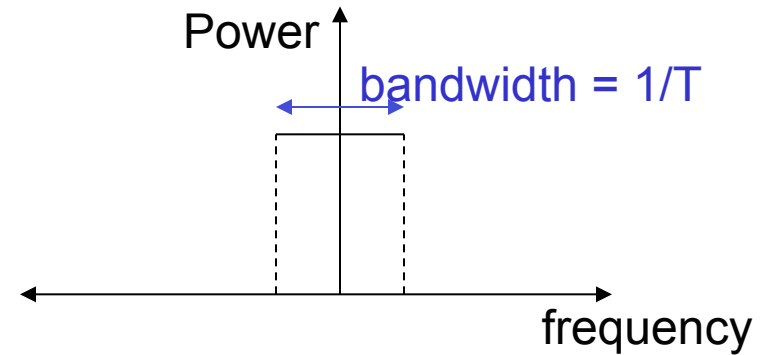

Wideband

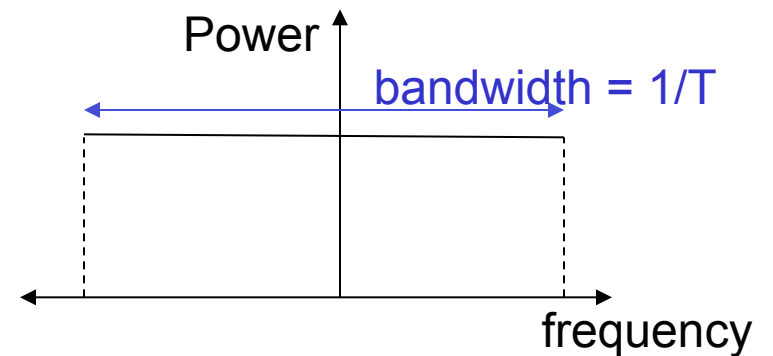

# Power-Delay Profile

Received power vs. time in response to a transmitted short pulse.

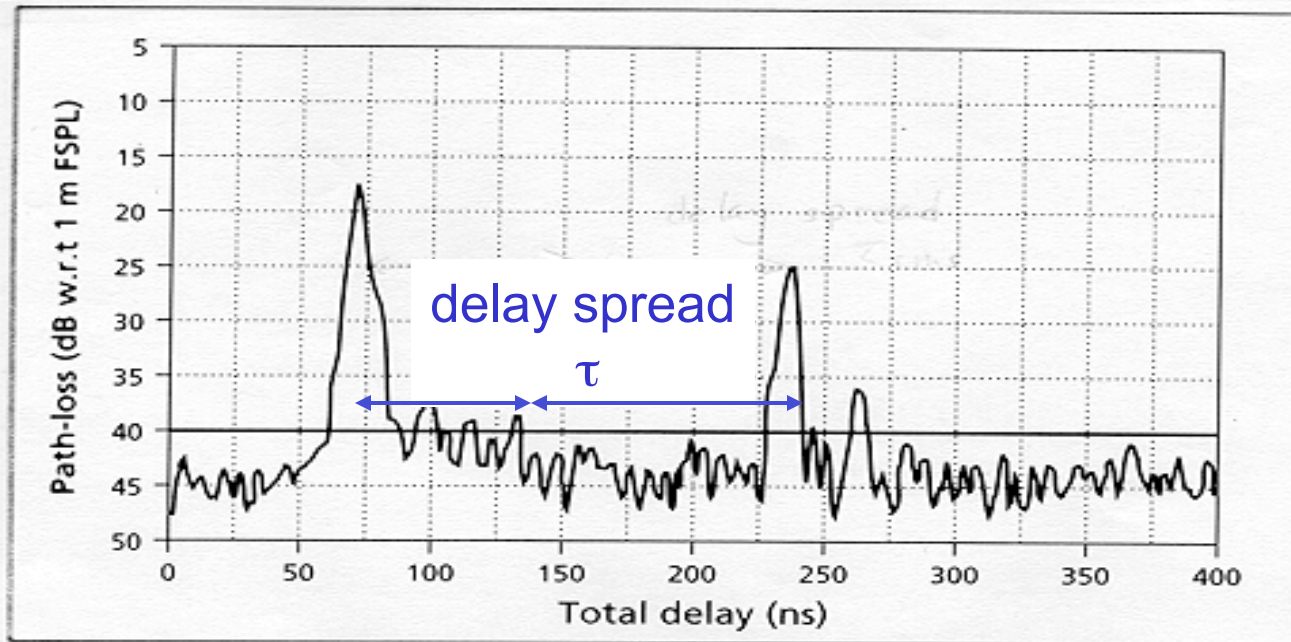
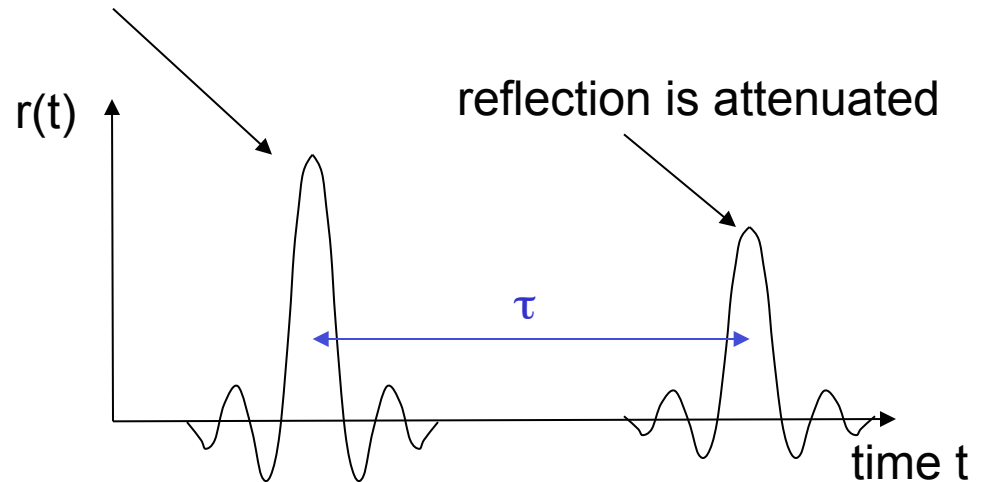
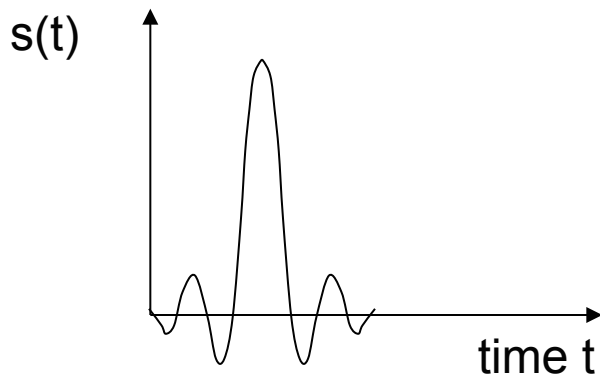
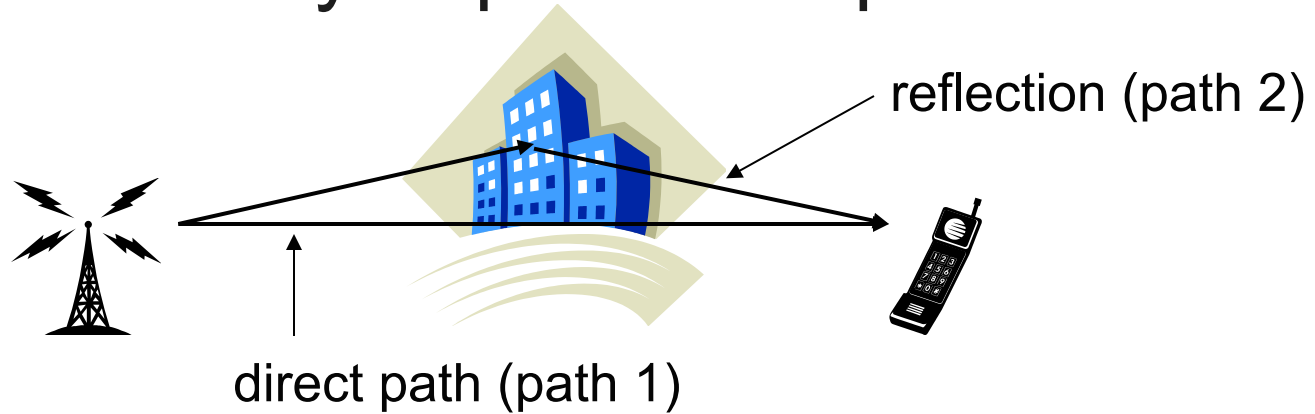

**Figure 8** Typical power-delay profile inside a building. T-R separation: 21.4m; Rms delay spread: 61.5 ns; Threshold: 40.0 dB

For cellular systems (outdoors), the delay spread is typically a few microseconds.



# Two-Ray Impulse Response



$$\tau = [(\text{length of path 2}) - (\text{length of path 1})]/c$$



# Urban Multipath

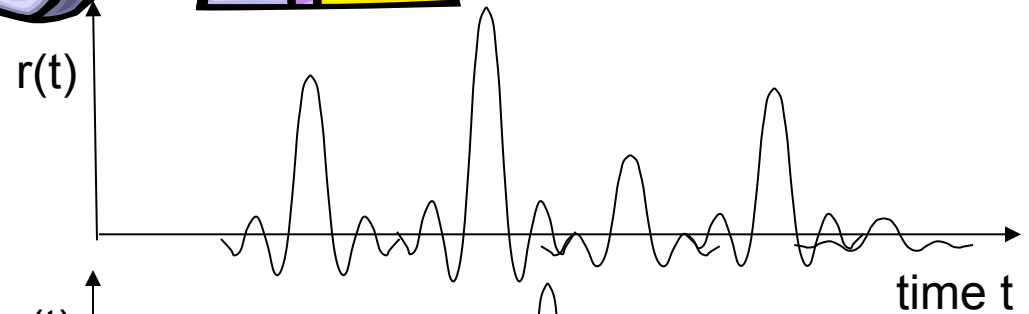
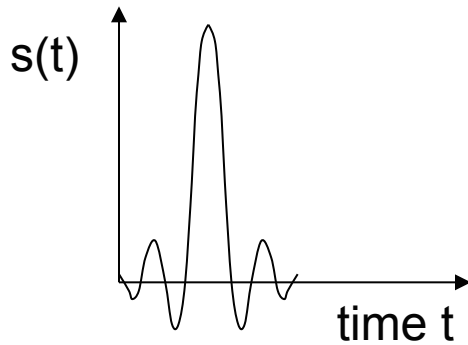

different location  
for receiver

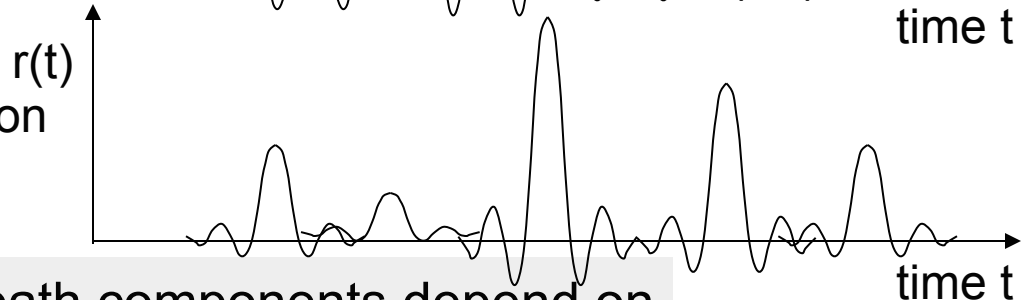

Spacing and attenuation of multipath components depend on location and environment.



# Multipath and Intersymbol Interference

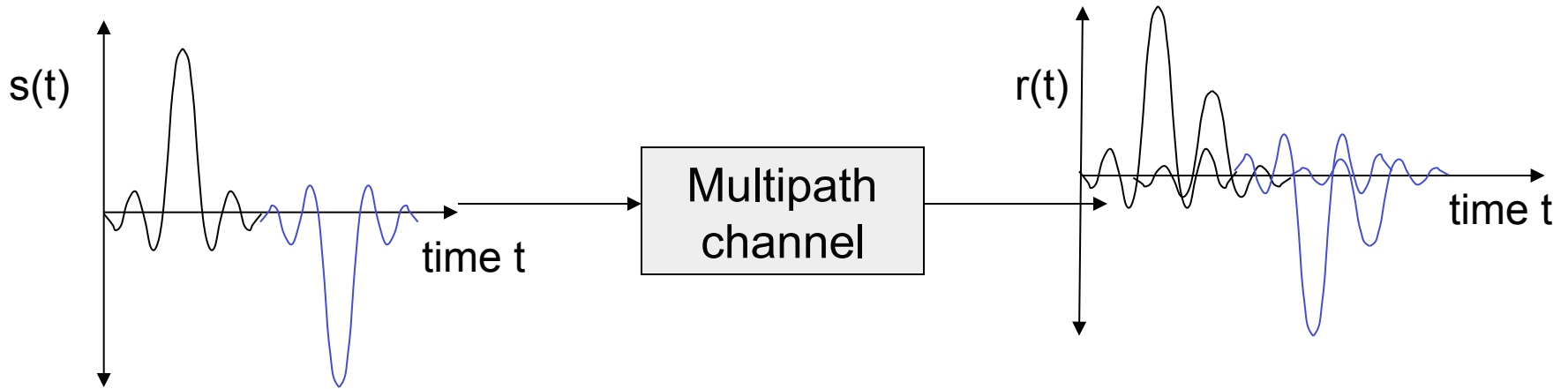

Time between pulses is  $\gg$  delay spread, therefore the received pulses do not interfere.

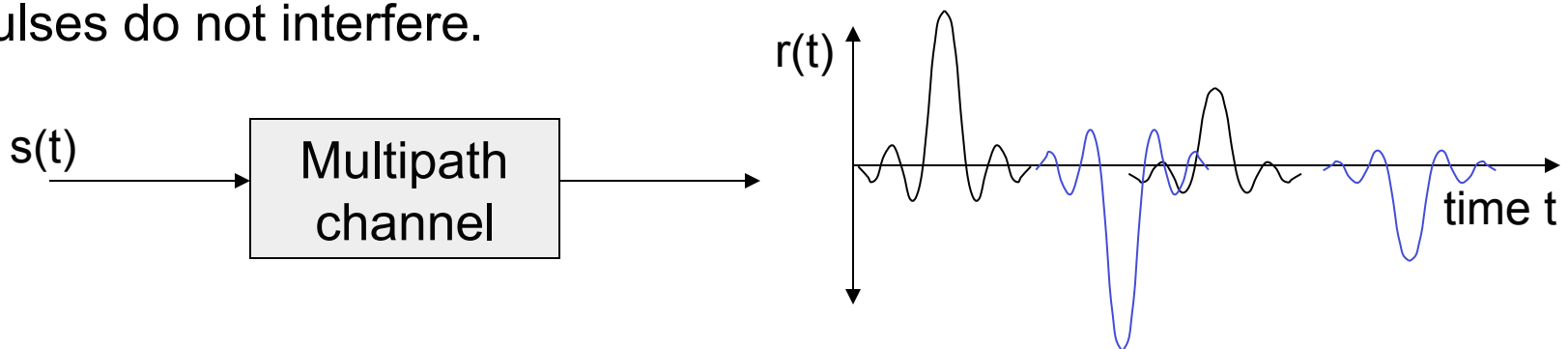

Time between pulses is  $<$  multipath delay, which causes intersymbol interference.



# Coherence Bandwidth

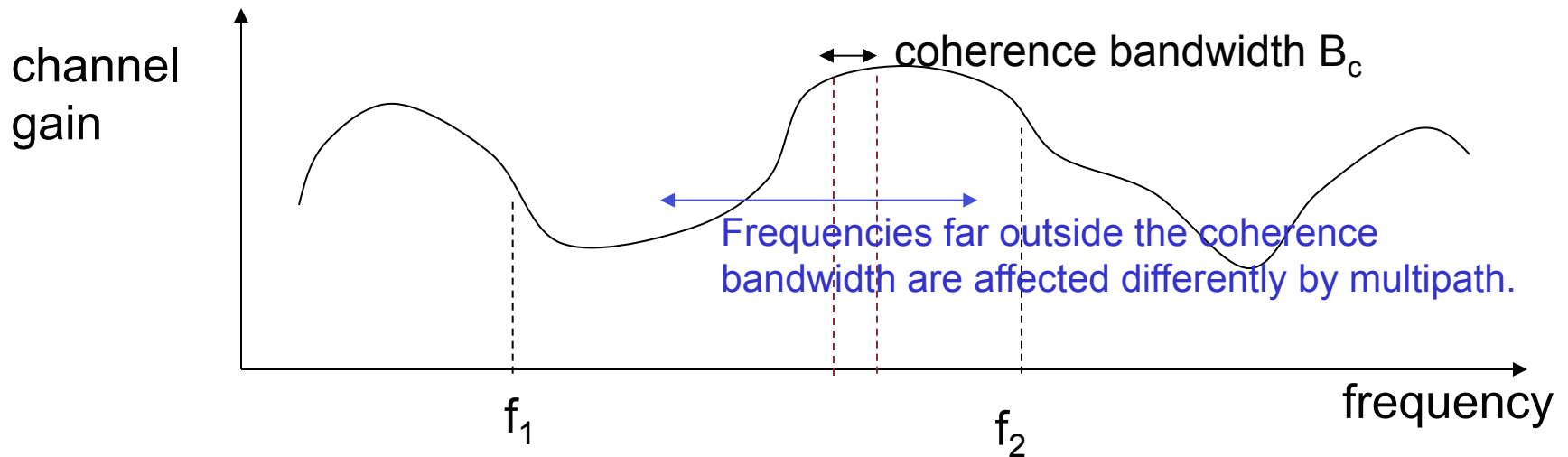

- The channel gain is approximately constant within a coherence bandwidth  $B_c$ .
- Frequencies  $f_1$  and  $f_2$  fade **independently** if  $|f_1 - f_2| \gg B_c$ .



# Coherence Bandwidth and Delay Spread

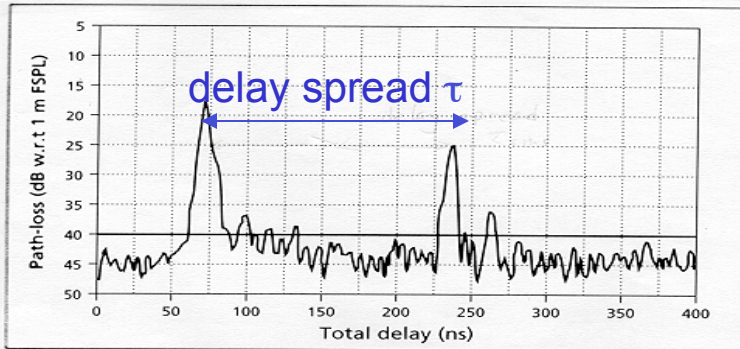

Figure 8 Typical power-delay profile inside a building. T-R separation: 21.4m; Rms delay spread: 61.5 ns; Threshold: 40.0 dB

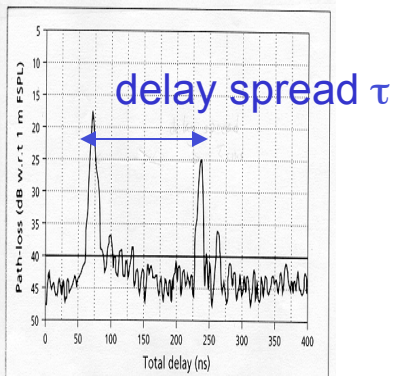
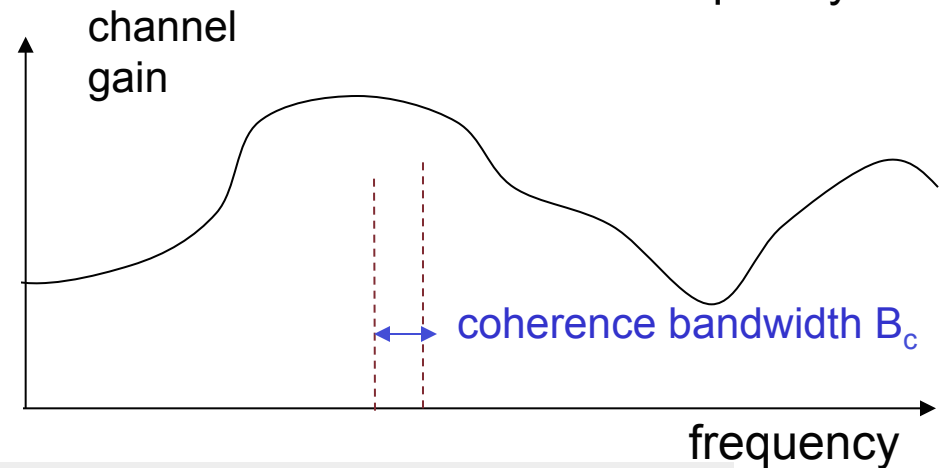
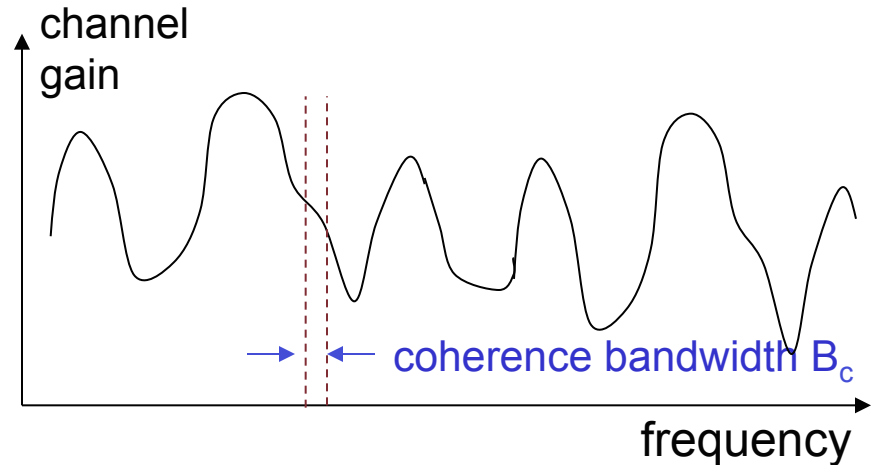
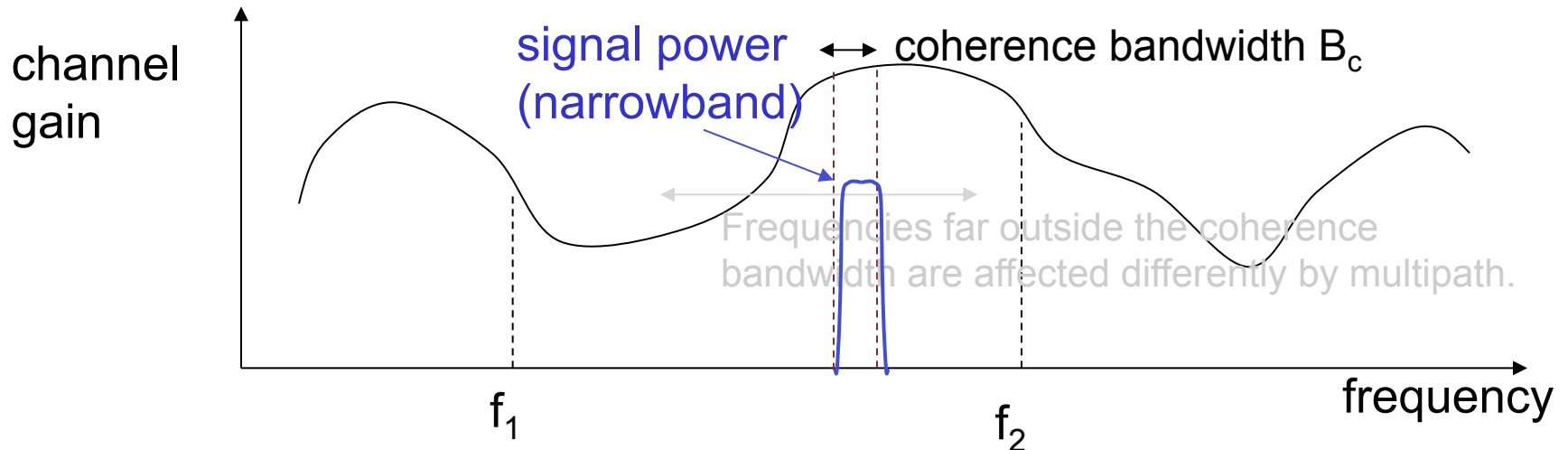

Figure 9 Typical power-delay profile inside a building. T-R separation: 21.4m; Rms delay spread: 61.5 ns; Threshold: 40.0 dB

Coherence bandwidth is inversely proportional to delay spread:  
 $B_c \approx 1/\tau$ .



# Narrowband Signal



- The signal power is confined within a coherence band.
- **Flat fading:** all signal frequencies are affected the same way.



# Wideband Signals

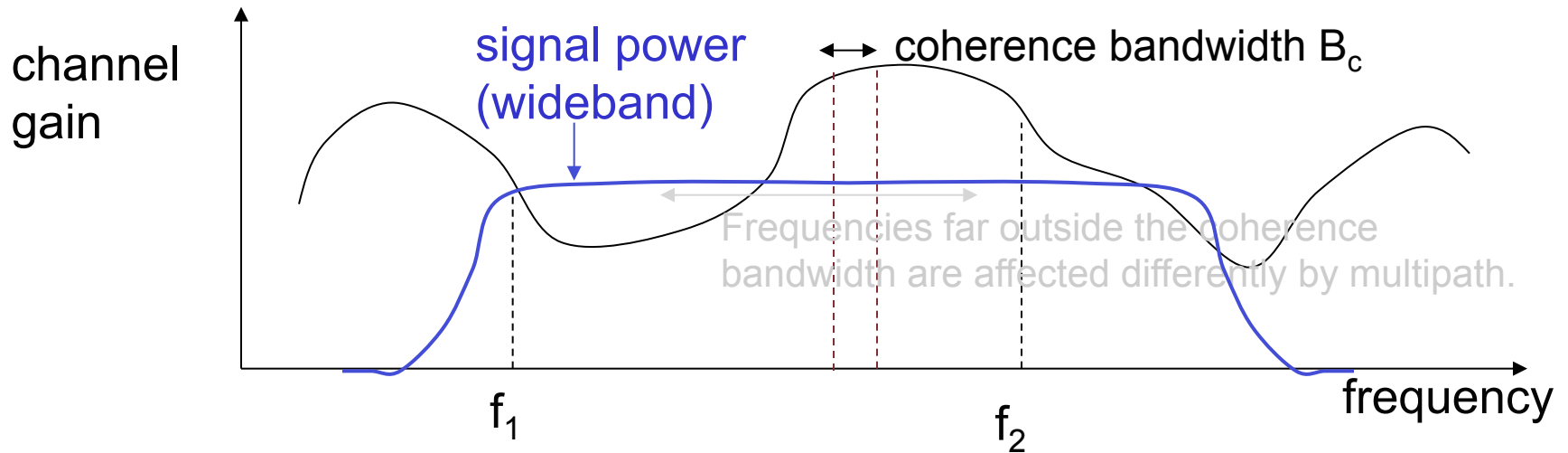

- A wideband signal spans **many** coherence bands.
- **Frequency-selective fading**: different parts of the signal (in frequency) are affected differently by the channel.



# Frequency Diversity

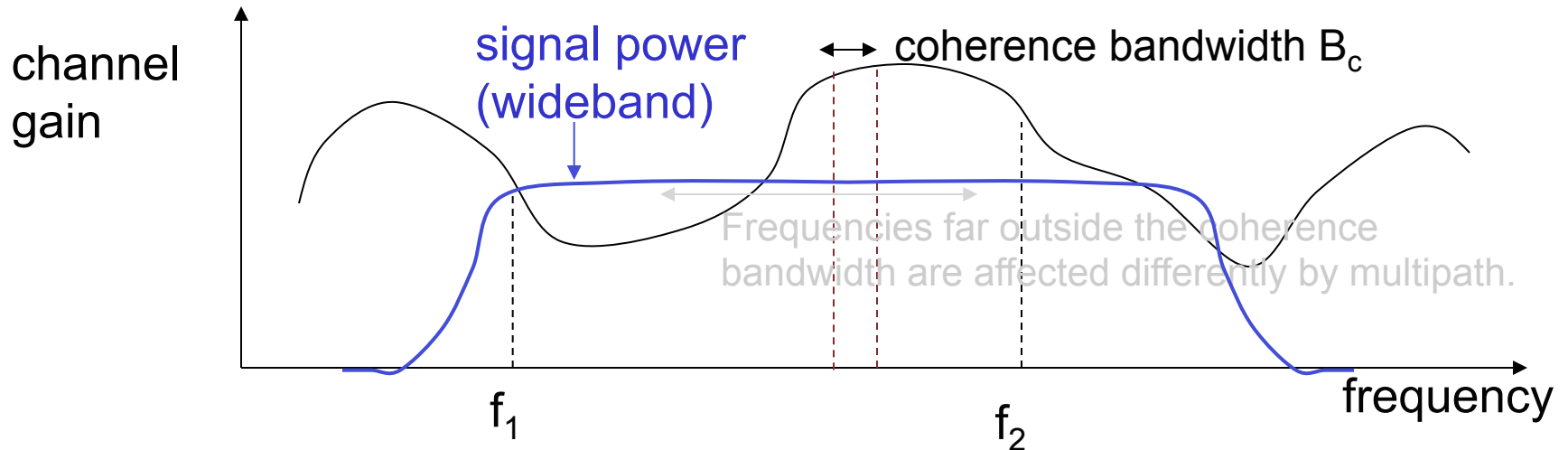

Wideband signals exploit **frequency diversity**.  
Spreading power across many coherence bands reduces the chances of severe fading.

Wideband signals are distorted by the channel fading (distortion causes intersymbol interference).



# Coherence Bandwidth for Cellular

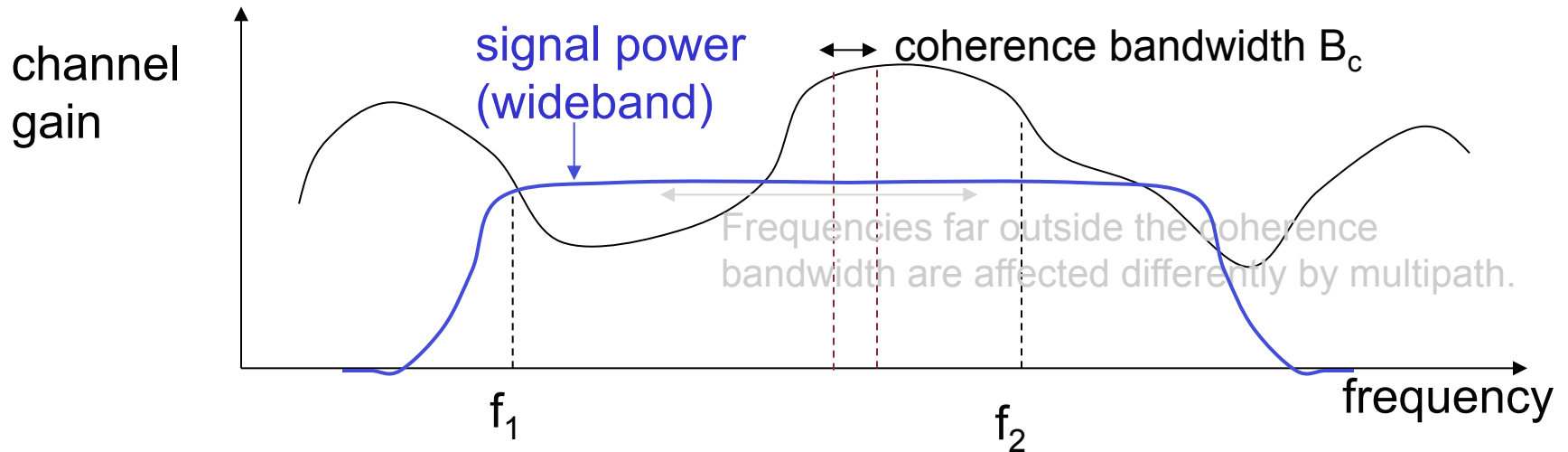

For the cellular band,  $B_c$  is around 100 to 300 kHz.  
How does this compare with the bandwidth of cellular systems?



## Fading Experienced by Wireless Systems

Standard	Bandwidth	Fade rate
AMPS	30 kHz (NB)	Fast
IS-136	30 kHz	Fast
GSM	200 kHz	Slow
IS-95 (CDMA)	1.25 MHz (WB)	Fast
3G	1.25-5 MHz	Slow to Fast (depends on rate)
LTE	up to 20 MHz	Slow
802.11	> 20 MHz	Slow
Bluetooth	> 5 MHz (?)	Slow



# Pulse Width vs. Bandwidth

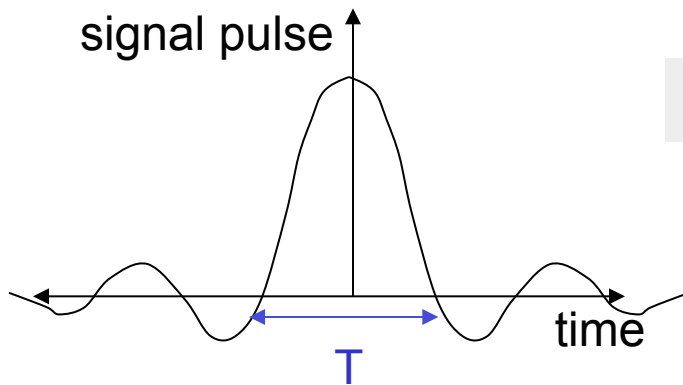

Narrowband

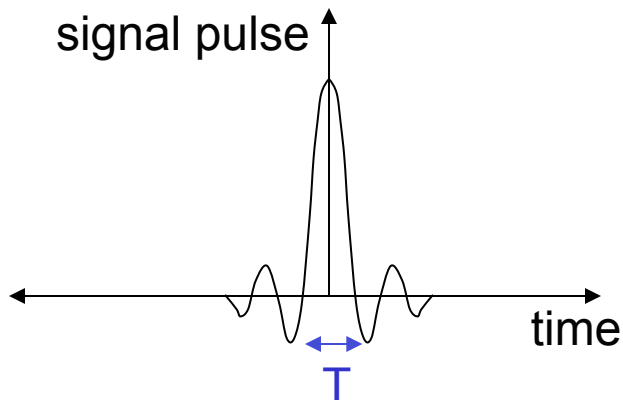
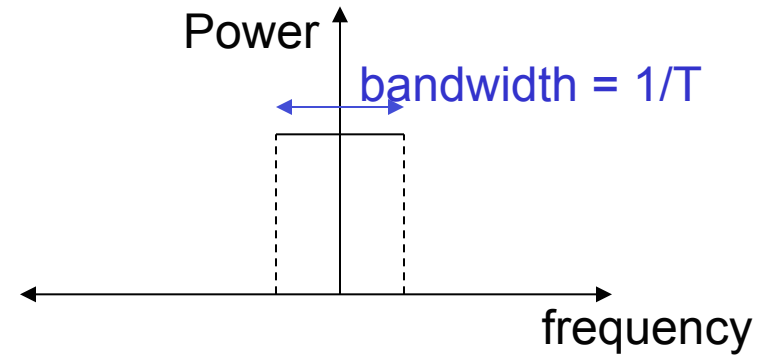

Wideband

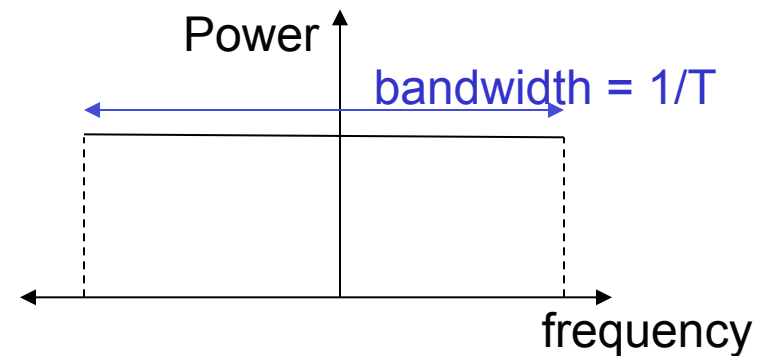



# Radar Pulse Bandwidth

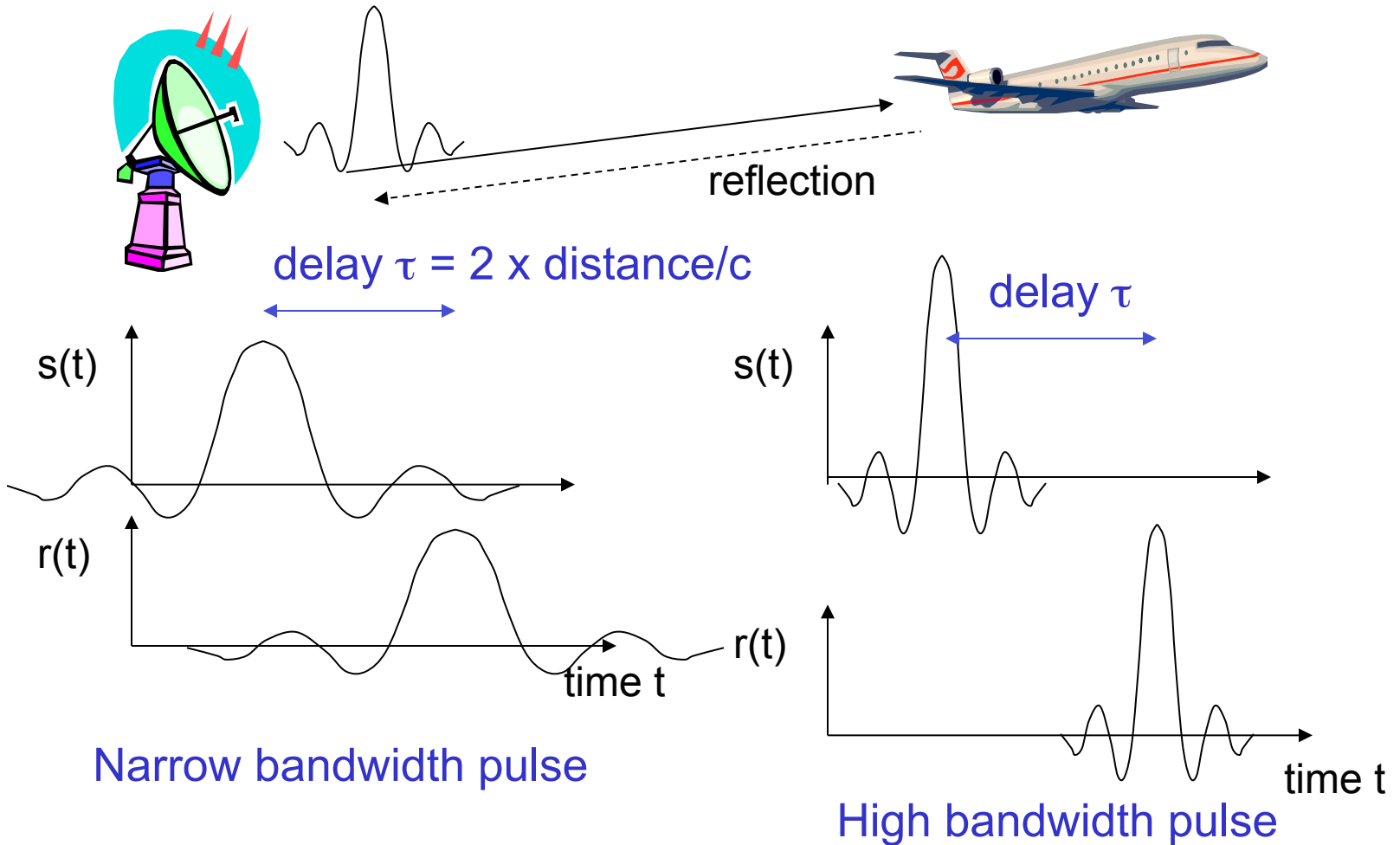

# Bandwidth and Resolution

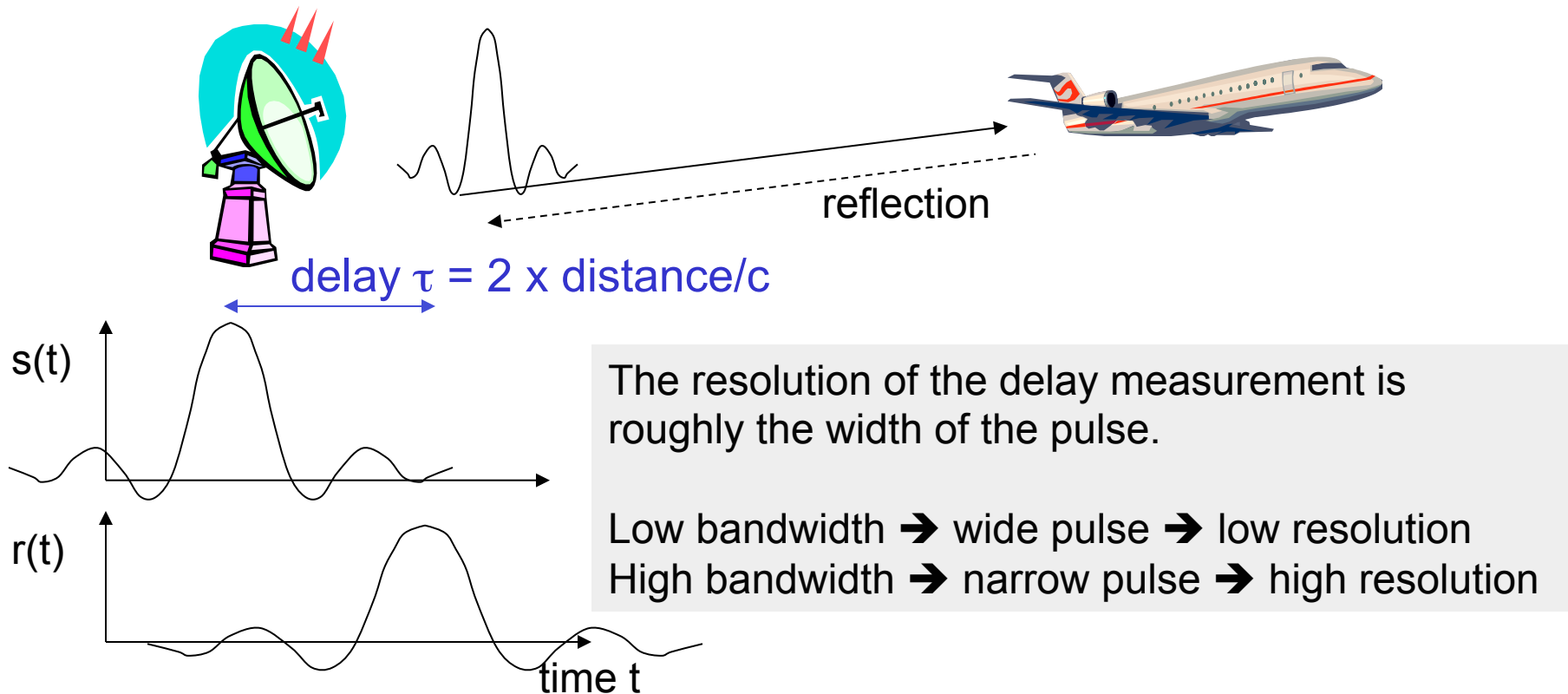

If the delay measurement changes by 1 microsec, the distance error is  $c \times 10^{-6}/2 = 150$  meters!



## Propagation and Handoff

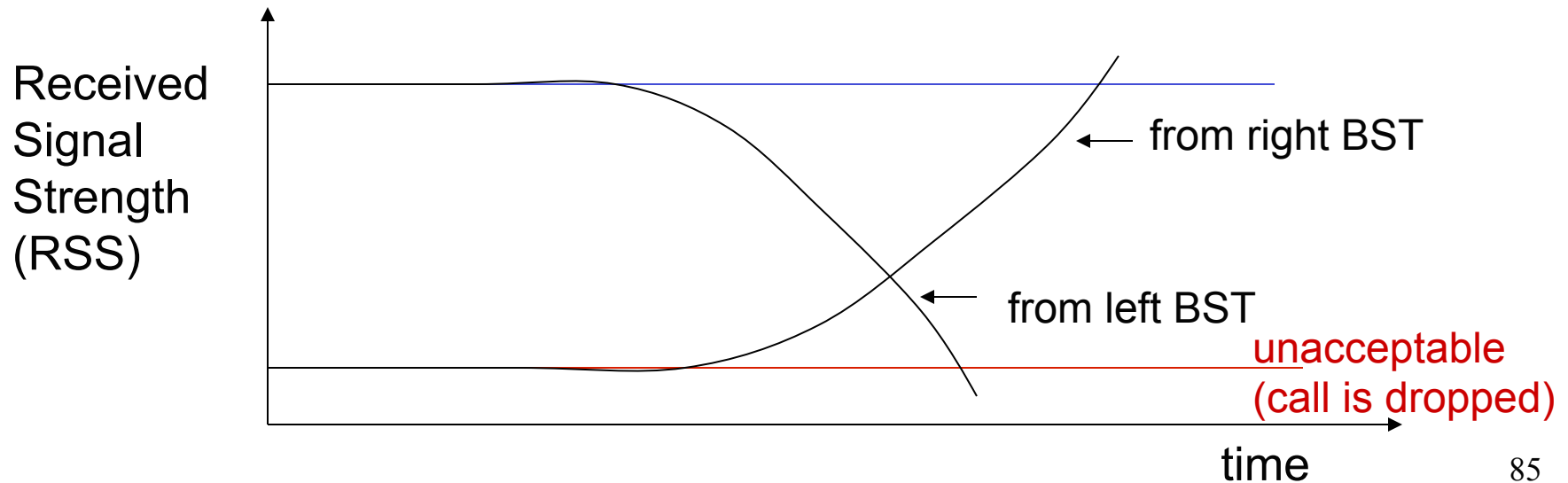
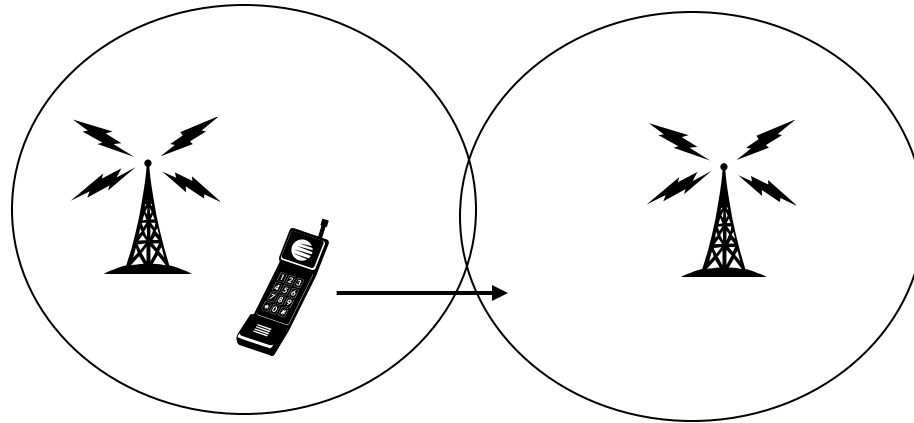



# Propagation and Handoff

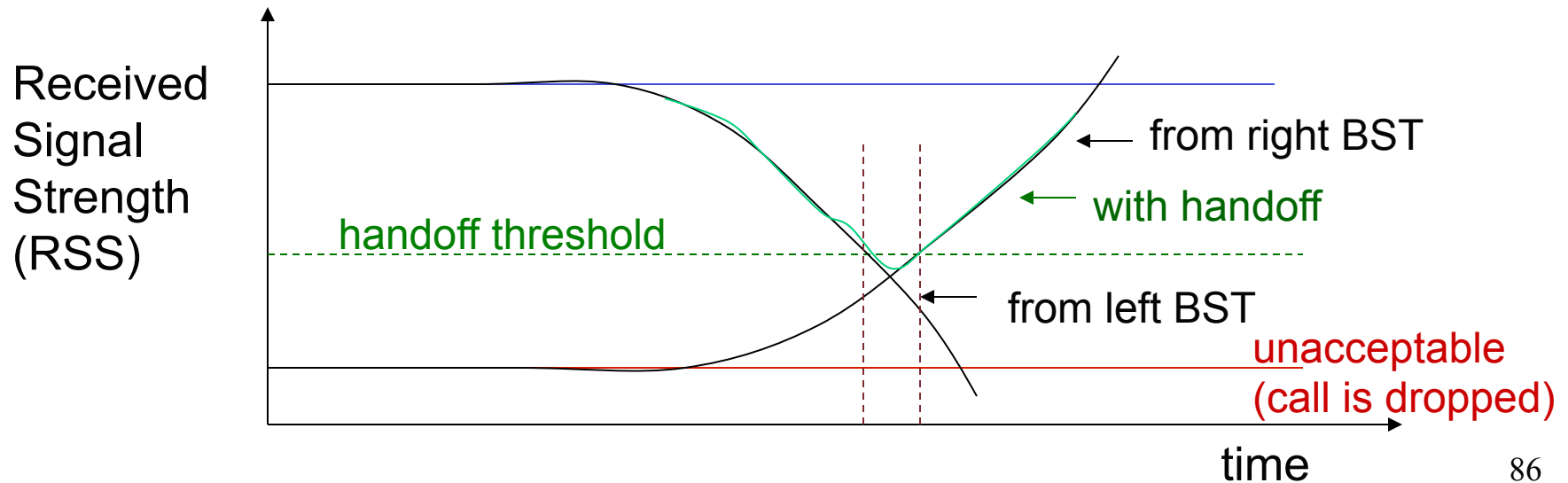
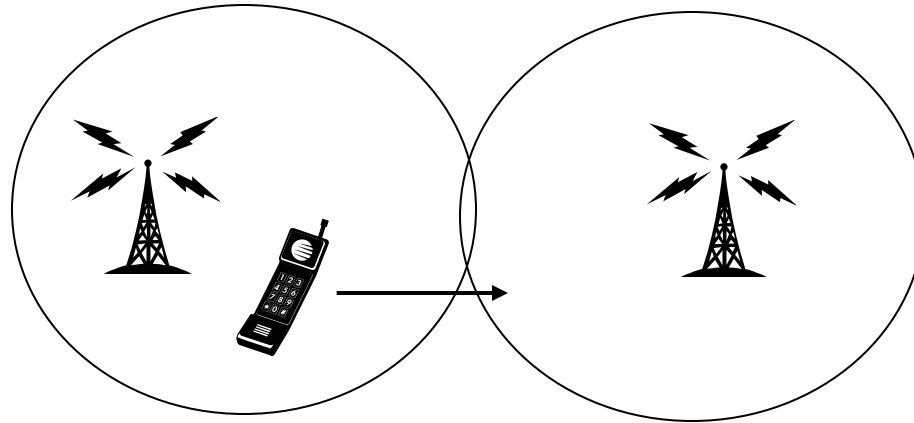



# Propagation and Handoff

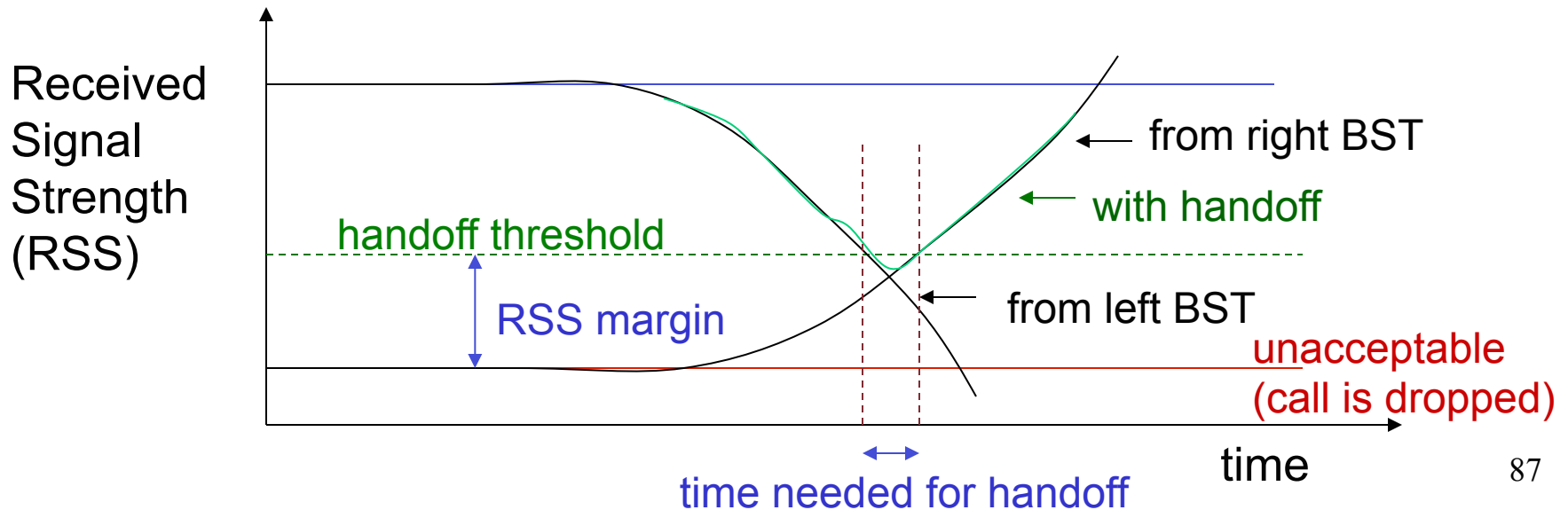
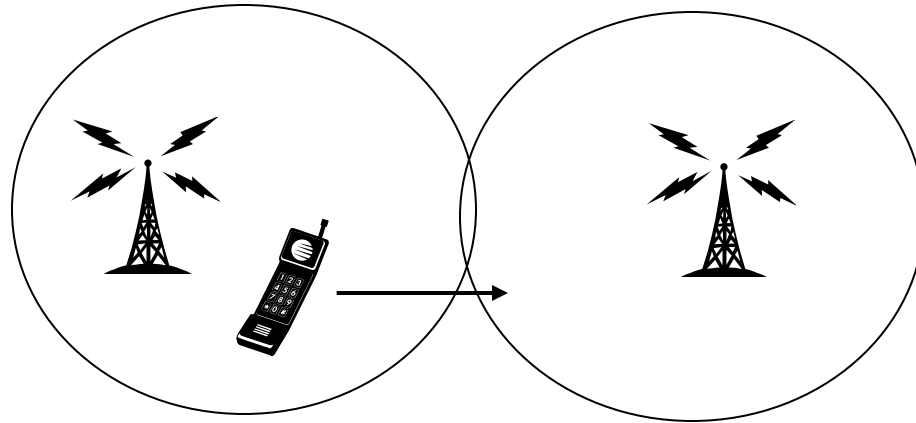



# Propagation and Handoff

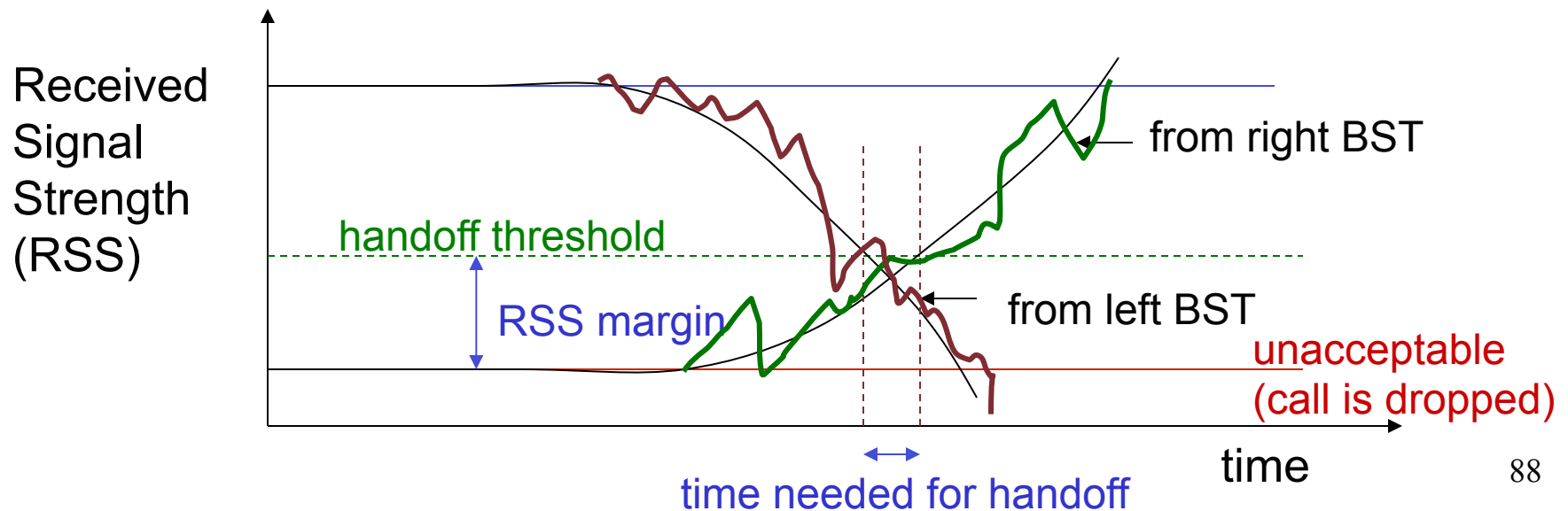
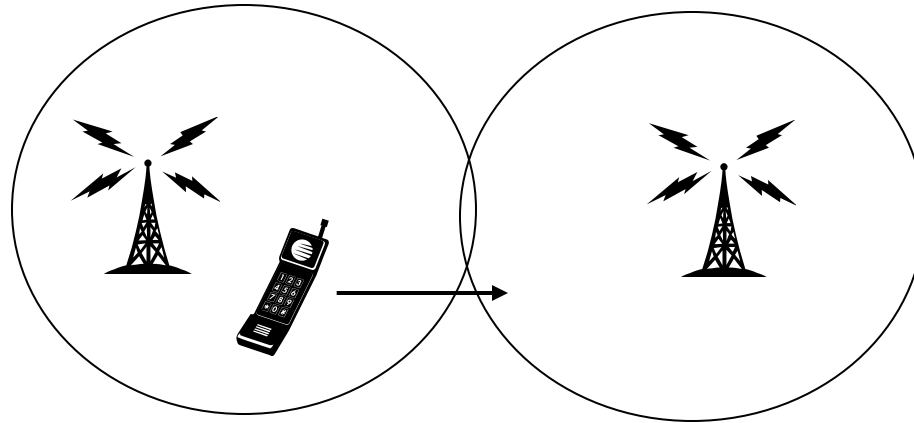



## Handoff Threshold

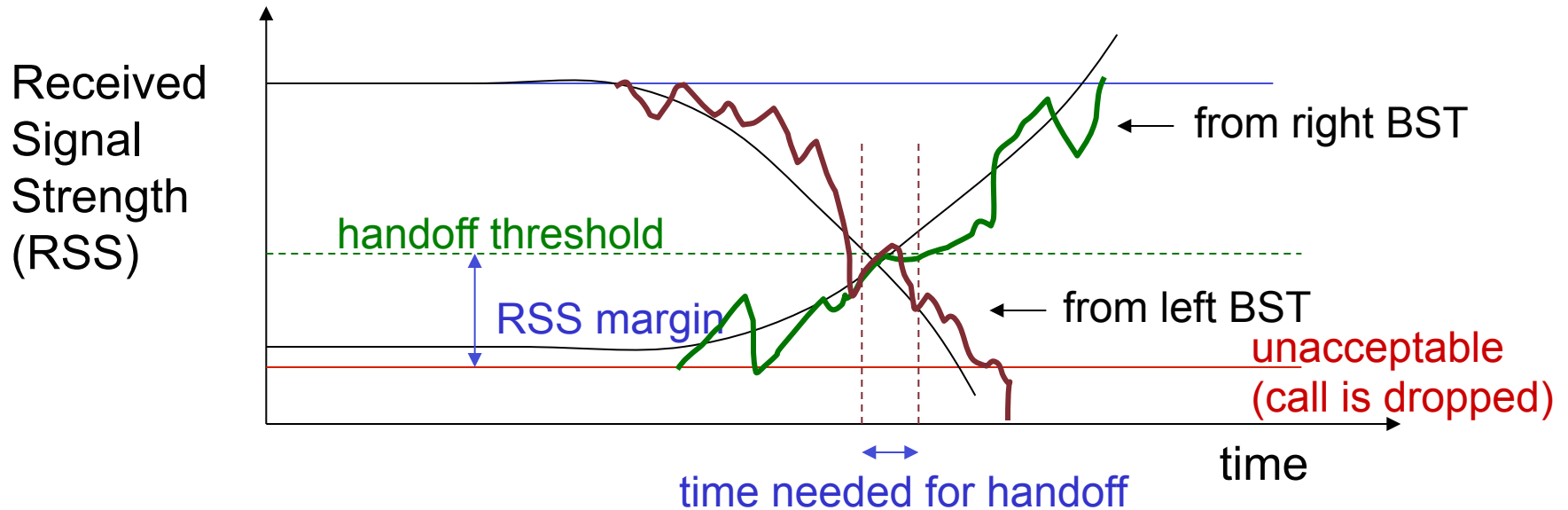

- Handoff threshold too high → too many handoffs (ping pong)
- Handoff threshold too low → dropped calls are likely
- Threshold should depend on slope on vehicle speed (Doppler).



## Handoff Measurements (3G)

- Mobile maintains a list of neighbor cells to monitor.
- Mobile periodically measures signal strength from BST pilot signals.
- Mobile sends measurements to network to request handoff.
- Handoff decision is made by network.

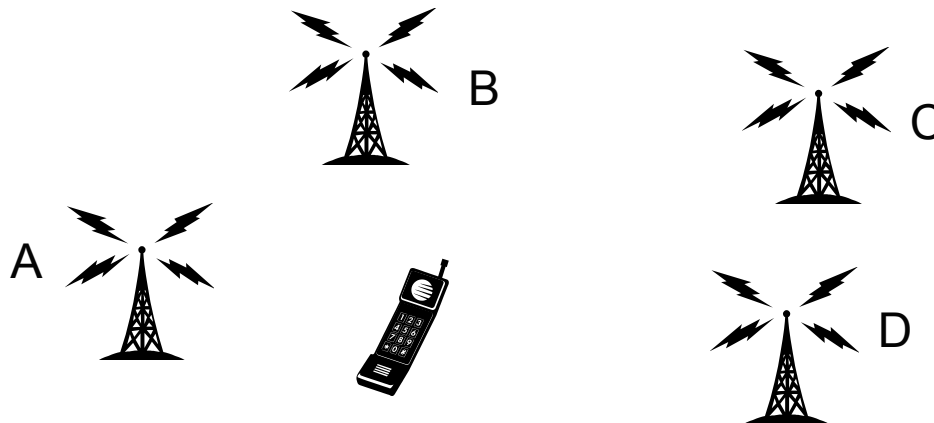

## Handoff Measurements (3G)

- Mobile maintains a list of neighbor cells to monitor.
- Mobile periodically measures signal strength from BST pilot signals.
- Mobile sends measurements to network to request handoff.
- Handoff decision is made by network.

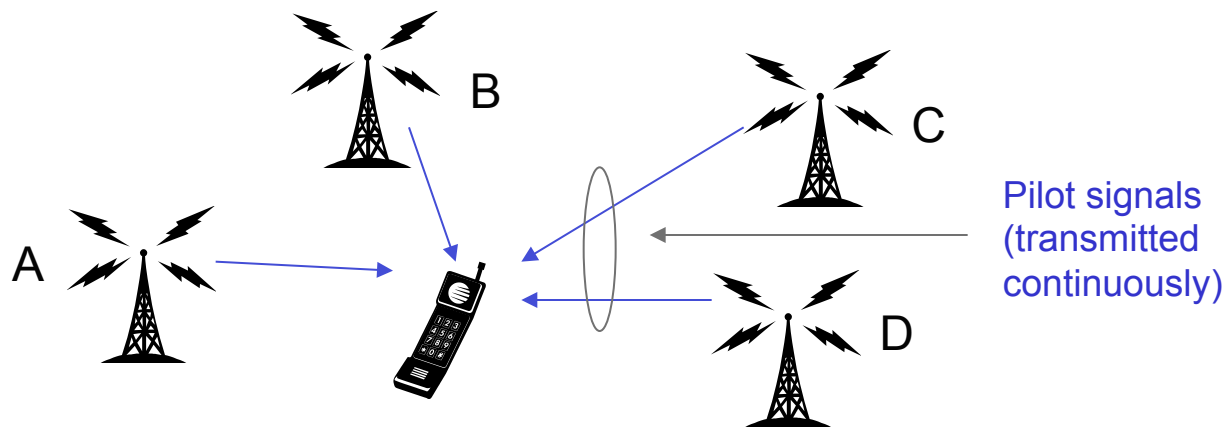

## Handoff Measurements (3G)

- Mobile maintains a list of neighbor cells to monitor.
- Mobile periodically measures signal strength from BST pilot signals.
- Mobile sends measurements to network to request handoff.
- Handoff decision is made by network.

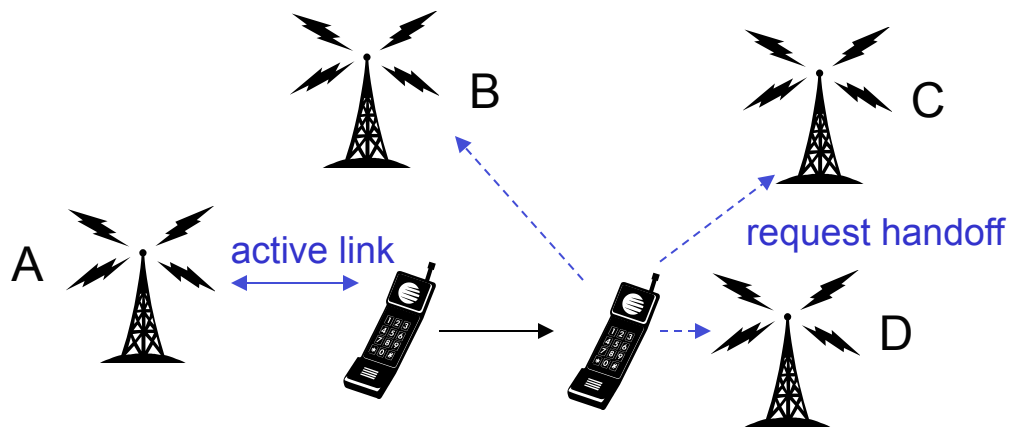



## Handoff Measurements (3G)

- Mobile maintains a list of neighbor cells to monitor.
- Mobile periodically measures signal strength from BST pilot signals.
- Mobile sends measurements to network to request handoff.
- Handoff decision is made by network.

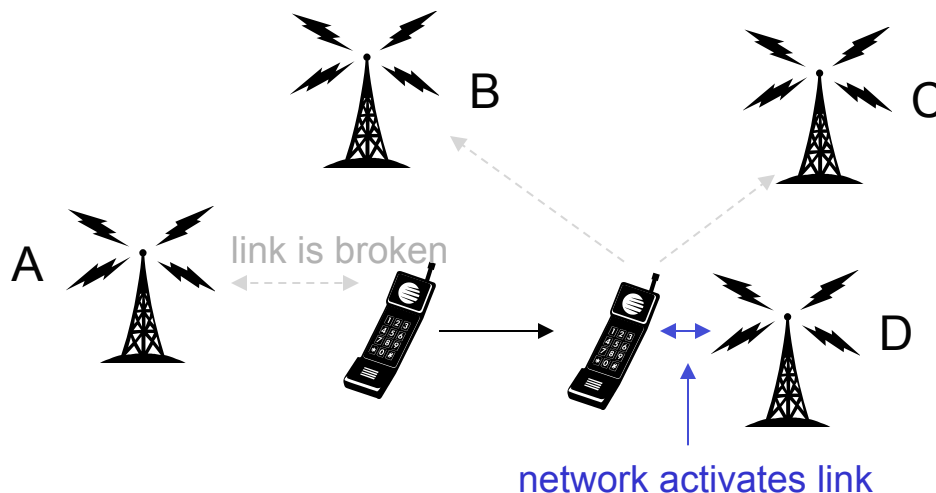



## Handoff Measurements (3G)

- Mobile maintains a list of neighbor cells to monitor.
- Mobile periodically measures signal strength from BST pilot signals.
- Mobile sends measurements to network to request handoff.
- **Handoff decision is made by network.**
  - Depends on available resources (e.g., channels/time slots/codes). Handoffs take priority over new requests (why?).
  - Hysteresis needed to avoid handoffs due to rapid variations in signal strength.

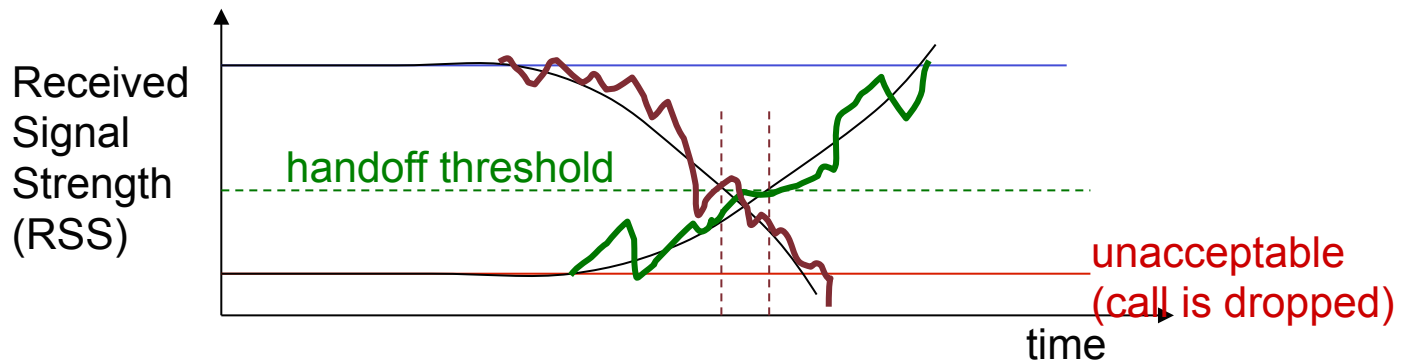



## Handoff Decision

- Depends on RSS, time to execute handoff, hysteresis, and dwell (duration of RSS)
  - Proprietary methods
  - Handoff may also be initiated for balancing traffic.
- 1G (AMPS): Network Controlled Handoff (NCHO)
  - Handoff is based on measurements at BS, supervised by MSC.
- 2G, GPRS, 3G: Mobile Assisted Handoff (MAHO)
  - Handoff relies on measurements at mobile
  - Enables faster handoff
- Mobile data, WLANs (802.11): Mobile Controlled Handoff (MCHO)
  - Handoff controlled by mobile



---

# Example Diagnostic Measurements: 1XEV-DO

drive test measurements

drive path